

MCMC MTSFB TC G026:2020

# TECHNICAL CODE

## RADIOCOMMUNICATIONS NETWORK FACILITIES - STREET FURNITURE

Developed by



Registered by



Registered date:

**20 May 2020**

© Copyright 2020

## **MCMC MTSFB TC G026:2020**

### **Development of technical codes**

The Communications and Multimedia Act 1998 ('the Act') provides for Technical Standards Forum designated under section 184 of the Act or the Malaysian Communications and Multimedia Commission ('the Commission') to prepare a technical code. The technical code prepared pursuant to section 185 of the Act shall consist of, at least, the requirement for network interoperability and the promotion of safety of network facilities.

Section 96 of the Act also provides for the Commission to determine a technical code in accordance with section 55 of the Act if the technical code is not developed under an applicable provision of the Act and it is unlikely to be developed by the Technical Standards Forum within a reasonable time.

In exercise of the power conferred by section 184 of the Act, the Commission has designated the Malaysian Technical Standards Forum Bhd ('MTSFB') as a Technical Standards Forum which is obligated, among others, to prepare the technical code under section 185 of the Act.

A technical code prepared in accordance with section 185 shall not be effective until it is registered by the Commission pursuant to section 95 of the Act.

For further information on the technical code, please contact:

#### **Malaysian Communications and Multimedia Commission (MCMC)**

MCMC Tower 1  
Jalan Impact  
Cyber 6  
63000 Cyberjaya  
Selangor Darul Ehsan  
MALAYSIA

Tel: +60 3 8688 8000  
Fax: +60 3 8688 1000  
<http://www.mcmc.gov.my>

OR

#### **Malaysian Technical Standards Forum Bhd (MTSFB)**

Malaysian Communications & Multimedia Commission (MCMC)  
Off Persiaran Multimedia  
Jalan Impact  
Cyber 6  
63000 Cyberjaya  
Selangor Darul Ehsan  
MALAYSIA

Tel: +60 3 8320 0300  
Fax: +60 3 8322 0115  
<http://www.mtsfb.org.my>

**Contents**

	<b>Page</b>
Committee representation.....	ii
Foreword .....	iii
0. Introduction.....	1
1. Scope .....	1
2. Normative references .....	1
3. Abbreviations.....	1
4. Terms and definitions .....	2
4.1 Auto-reclose .....	2
4.2 Contractor.....	2
4.3 Gap-filler/in-fill .....	2
4.4 Installer.....	2
4.5 Macro site.....	2
4.6 Micro site .....	2
4.7 Operator .....	2
4.8 Purchaser .....	2
4.9 Radiocommunications network facilities .....	3
4.10 Street furniture .....	3
5. General requirement .....	3
5.1 Civil, Mechanical and Electrical (CME) .....	3
5.2 Aesthetic.....	9
5.3 Right of Way (RoW) .....	9
6. Technical requirement.....	9
6.1 Radiocommunications network facilities .....	9
6.2 Backhaul.....	16
6.3 Operation and maintenance.....	16
6.4 Safety and security.....	17
Annex A Normative references.....	19
Annex B Design criteria and codes.....	21
Bibliography .....	24

## **MCMC MTSFB TC G026:2020**

### **Committee representation**

The technical code was developed by Radiocommunications Network Facilities (External) Sub Working Group under the Radio Network Facilities Working Group of the Malaysian Technical Standards Forum Bhd (MTSFB) which consists of representatives from the following organisations:

Celcom Axiata Berhad

Digi Telecommunications Sdn Bhd

edotco Malaysia Sdn Bhd

Malaysia Digital Economy Corporation

Maxis Bhd

MEASAT Broadcast Network Systems

Redsun Engineering Sdn Bhd

Telekom Malaysia Bhd

TIME dotCom Berhad

U Mobile Sdn Bhd

webe digital sdn bhd

YTL Communications Sdn Bhd

Zettabits Technologies

## **Foreword**

This technical code for the Radiocommunications Network Facilities - Street Furniture ('this Technical Code') was developed pursuant to section 95 and section 185 of the Act 588 by the Malaysian Technical Standards Forum Bhd (MTSFB) via its Radiocommunications Network Facilities (External) Sub Working Group under the Radio Network Facilities Working Group Radio Network Facilities Working Group.

This Technical Code shall continue to be valid and effective from the date of its registration until it is replaced or revoked.

(THIS PAGE IS INTENTIONALLY LEFT BLANK)

## RADIOCOMMUNICATIONS NETWORK FACILITIES - STREET FURNITURE

### 0. Introduction

Communication systems play a vital role in daily life and have become a social obligation to the people in helping to generate the economy of the country and state. The digital revolution could become one of the criteria in contributing to the growth of the Gross Domestic Product (GDP), which is derived by digital products. Thus it is crucial to ensure all government aspirations are fulfilled and achieved.

This Technical Code is required to enhance the network coverage and capacity at street level, and in preparation for any future technologies.

The integration of street furniture with radiocommunications network facilities may address issues such as non-uniformity in design, cost efficiency and deployment speed.

### 1. Scope

This Technical Code provides the following:

- a) technical requirements for the installation of radiocommunications network facilities on new, existing or replacement structure of street furniture;
- b) design concepts used in the construction of street furniture for integration with radiocommunications network facilities which include structural, mechanical and electrical works; and
- c) safety requirements at sites during and after installation of radiocommunications network facilities on new, existing or replacement structure of street furniture.

### 2. Normative references

The following normative references are indispensable for the application of this Technical Code. For dated references, only the edition cited applies. For undated references, the latest edition of the normative reference (including any amendments) applies.

See Annex A.

### 3. Abbreviations

For the purposes of this Technical Code, the following abbreviations apply.

AC	Alternating Current
AMS	Antenna Mounting Structure
CMA	Communications and Multimedia Act
CME	Civil, Mechanical and Electrical
DC	Direct Current
GDP	Gross Domestic Product
MIMS	Mineral-Insulated Mineral Sheathed

## **MCMC MTSFB TC G026:2020**

PVC	Polyvinyl Chloride
RCCB	Residual Current Circuit Breaker
RF	Radio Frequency
RoW	Right of Way
RRU	Remote Radio Unit
TX	Transmit
UTP	Unshielded Twisted Pair

### **4. Terms and definitions**

For the purposes of this Technical Code, the following terms and definitions apply.

#### **4.1 Auto-reclose**

A type of circuit breaker equipped with a mechanism to automatically close the breaker after it has been opened due to a fault.

#### **4.2 Contractor**

An entity who undertakes a contract to provide materials or services at a mutually agreed specification, price and timeline.

#### **4.3 Gap-filler/in-fill**

Installation of radiocommunications network facilities to improve radio network coverage in an area where the reception is poor or to overcome congestion issues.

#### **4.4 Installer**

The party who is responsible for the installation of radiocommunications network facilities on-site.

#### **4.5 Macro site**

A radiocommunications network site serving large coverage areas whereby radiocommunications network facilities with high-power consumption are installed at a height that provides a clear view over the surrounding buildings and terrain.

#### **4.6 Micro site**

A radiocommunications network site serving small coverage areas whereby radiocommunications network facilities with low power consumption are installed at lower height and normally act as a gap-filler/in-fill.

#### **4.7 Operator**

A network facilities provider or a network service provider as defined in the CMA 1998.

#### **4.8 Purchaser**

An entity that contracts a contractor for materials or services at a mutually agreed specification, price and timeline.



#### **4.9 Radiocommunications network facilities**

Any element or combination of elements of physical infrastructure used principally for, or in connection with, the provision of radiocommunications services.

#### **4.10 Street furniture**

Any new or existing objects in public spaces such as street lamp post, flood light, overhead bridge, gantry street signage, bus stop, information board, way finder, digital signage, traffic light, waste bin, sitting bench, public art, cabinet and any other object along the road, either built or owned by the state authorities, local authorities or private entities, which can be integrated with radiocommunications network facilities.

### **5. General requirement**

This clause details the generic design requirements for street furniture for the deployment of mobile network. The street furniture is designed to provide coverage for blind spot (gap filler/in-fill) that is not able to be addressed by the conventional macro sites such as tower, monopole, lamp pole and rooftop sites.

Continuous demands towards better experience of communications services have brought the installation of radiocommunications network facilities on street furniture into the market, with its main objective is to resolve capacity and blind spot issues.

Radiocommunications network facilities on street furniture is expected to be deployed in an area where normally macro sites are ideal or gap-filler/in-fill is required, such as by the roadside and public spaces in urban areas.

Radiocommunications network facilities on street furniture should be aesthetically blended into its environment.

Radiocommunications network facilities on street furniture shall co-exist with existing macro sites since the deployments are not meant to replace the macro sites.

Existing street furniture is required to be replaced with new structure if the following requirements are not complied.

- a) The installation of radiocommunications network facilities on existing street furniture does not meet the loading safety factor.
- b) The design of the existing street furniture is unable to support the installation of radiocommunications network facilities.

The installation of radiocommunications network facilities on street furniture may be subjected to the relevant laws and regulations as well as approval by the relevant authorities.

#### **5.1 Civil, Mechanical and Electrical (CME)**

Radiocommunications network facilities on existing or new street furniture shall be in compliance with the Civil, Mechanical and Electrical (CME) requirements as stipulated in this clause.

The specifications of equipment cabinet and street lighting pole to cater for the installation of radiocommunications network facilities are as defined in Table 1.

## MCMC MTSFB TC G026:2020

**Table 1. Specification of equipment cabinet and street lighting pole**

Type of coverage	Type of street lighting pole	Cabinet dimension (H x W x D) (mm)	Pole height (m)	Pole diameter (mm)
Macro	A1: Street lighting pole with cabinet on ground	1 800 x 2 000 x 1 400	15 to 18	a) Top section is 180 b) Bottom section is 400
	A2: Street lighting pole with equipment inside the pole ( $\leq 4$ radio technology)	-	15 to 18	c) Top section is 180 Bottom section is 600
Micro	A3: Street lighting pole with equipment cabinet mounted on pole	2 600 x 1 600 x 580	10 to 18	a) Top section is 180 b) Bottom section is 400
	A4: Street lighting pole with equipment inside the pole ( $\leq 2$ radio technology)	-	10 to 18	a) Top section is 180 b) Bottom section is 500
<i>Note: The pole height and diameter specified in this table only serve as a recommendation.</i>				

The specifications of equipment cabinet and street furniture other than street lighting pole are as defined in Table 2.

**Table 2. Specifications of equipment cabinet and street furniture other than street lighting pole**

Type of coverage	Type of street furniture	Cabinet dimension (H x W x D) (mm)	Antenna size	Type of cable
Micro	Road signage, overhead gantry pole, flood light, traffic light or pedestrian flyover (but not limited to)	700 x 400 x 600 NOTE: Applicable for mounted cabinet only.	Sectorised antenna size less than 1 200 mm	All cables to install and conceal with proper type of material
	Taxi stand or bus stop	Requirements depend on demand and necessity		
<i>Note: The cabinet dimension specified in this table only serves as a recommendation.</i>				

### 5.1.1 Street furniture design

All designs, materials and workmanship shall be, wherever relevant, in compliance to the requirements of the latest editions of the following standards:

- a) ISO 1461;
- b) MS 1553;
- c) MS 2112-3;

- d) MS 2112-4;
- e) MS IEC 62305;
- f) BS 499-1;
- g) BS 3692;
- h) BS 4592-2;
- i) BS 5493;
- j) BS EN 1011;
- k) BS EN 1993-3-1;
- l) BS EN 10210;
- m) BS ISO 5950;
- n) BS EN ISO 636;
- o) ANSI/TIA-222-G;
- p) ASCE Manual 72; and
- q) AS 3995.

**5.1.2 Basic design wind speeds**

The street furniture shall be designed for the purpose of assessing its structural strength to a basic design wind speed of 33 m/s (120 km/h), 3-second gust speed or 22 m/s mean hourly wind speed for all sites. This corresponds to a return period of 1:50 years. For the purpose of compliance check for maximum deflection (sway) and twist of the street furniture, 1:20 years return period wind speed of 30 m/s (3-second gust) or 20 m/s mean hourly wind speed shall be used.

**5.1.3 Design load**

The street furniture shall be designed with specific design load so that no failure or permanent distortion will occur on any part of the structure during simultaneous application of the loads. The specified loading configurations are shown in Table 3. Any additional equipment to be installed will be based on a load structure analysis of the existing or new street furniture.

**Table 3. Specified loading configuration**

Equipment type	Equipment dimension (m)	Number of equipment
Solid parabolic without radome	0.3	2
Flat antenna	2.10 H x 0.5 W x 0.21 D	3
Cluster antenna + pedestal	0.36 D x 1.8 H + 0.37 D x 0.32 H	1
Small cell	0.77 H x 0.17 W x 0.15 D	3
Remote Radio Unit (RRU)	-	3

## MCMC MTSFB TC G026:2020

The Radio Frequency (RF) feeder cable or Transmit (TX) cable arrangements are as stipulated in Table 4. Equipment quantity could vary but shall not exceed the total wind resistance area calculated as per Table 5.

**Table 4. Cable arrangements**

Type	Quantity	Dimension (inch)	Weight (kg/m)
0.5-inch RF feeder	12	12.5	0.5
TX cable	2	11	0.3
Unshielded Twisted Pair (UTP) cable	2	2	0.01
Fibre cable	6	6	0.01
Power cable	6	35	1

These antenna elements and all related cables shall be arranged in such a manner that the resulting bending moment and shear forces are the greatest. The deflection under the relevant design wind speed shall be maximum irrespective of the direction of antenna and/or the direction of incident wind and shall not be limited to any pattern or direction of antenna arrangement.

### 5.1.4 Erection marking

All members shall be marked with distinguishing numbers and alphabets corresponding to the erection drawings or bill of materials. The erection marks shall be done before galvanising and shall be clearly legible afterwards.

The erection marks shall be at least 12 mm height from each member base, clearly legible and shall be stamped at easily locatable positions.

### 5.1.5 Galvanising

The galvanising coating shall be according to at least 610 g of zinc per square meter of surface and shall not be less than 0.086 mm (86 microns) thick and shall be able to withstand the test set out in ISO 1461.

### 5.1.6 Bolts and nuts

All connection bolts, nuts and spring washers that are to be used for member connections which shall conform to BS 3692. All bolts and nuts heads shall be in hexagonal shape.

Bolt holes shall not be more than 1.5 mm larger in diameter than the corresponding bolt diameter and free from burrs. The tolerance for location of centres of bolt holes shall be  $\pm 2$  mm.

All connection bolts and anchor bolts shall be galvanised including the threaded portion. All nuts shall be galvanised with the exception of the threads, which shall be greased.

When in position, each connection bolt shall project through its nut for at least a full turn but not exceeding 10 mm.

Each connection bolt shall be supplied as a set, complete with one nut, one spring washer and one flat washer.

Nuts shall be finger tight on the bolt and will be rejected if they are, in the opinion of the operator, considered to have excessively tight or loose fit.

The minimum distance from the centre of the bolt holes to a rolled edge shall be 1.25 x bolt diameter. The minimum distance between holes for multi-bolted joints shall be 3 x bolt diameter. The minimum distance from the centre of the bolt holes to a sheared edge shall be 1.5 x bolt diameter.

**5.1.7 Materials**

All designs shall be such that no trouble shall arise in service from vibration or excessive deflection due to the use of a very light section.

Rolled steel sections, flats, plates, bolts, nuts and bars shall, unless otherwise approved be of steel in accordance to BS 4360 or its latest equivalent and shall be manufactured and rolled in approved mills.

Steel shall be cleaned and free from blisters, rust and scale or other defects before hot dipping process. Minimum thickness of structural members (angle sections) shall be 5 mm. The ultimate design stresses in tensile members shall not exceed the elastic limit strength of the material, whereas the ultimate stresses in the compression members shall not exceed a figure calculated from an approved formula.

**5.1.8 Deflection limit**

The maximum twist and sway (deflection) at any specified elevation of the fully loaded street furniture (inclusive of all the designed antenna, accessories and radio feeders) shall not exceed 1.0 degree at a 1:20 year return period wind speed of 23.33 m/s 3-second gust or 15.56 m/s mean hourly wind speed. The gustiness of wind loading shall be included in the deflection assessment.

**5.1.9 Fabrication tolerances**

The length of a member shall not deviate from its specified length by more than  $\pm 3$  mm. Straightness of a member shall not exceed 3 mm for all non-hollow sections and 2.5 mm for all other sections.

**5.1.10 Loading configurations - Ancillary loadings**

The street furniture shall be designed to carry parabolic microwave dishes, flat panel antenna, cluster antenna and RF and TX cables of various combinations. For the purpose of design, it shall not exceed the parameters as shown in Table 5.

**Table 5. Design parameters**

<b>Loading type</b>	<b>Loading Dimension (m)</b>	<b>Weight per unit (kg)</b>	<b>Wind resistance area (m<sup>2</sup>)</b>
Solid parabolic without radome	0.3	15	0.28
Flat antenna	2.10 H x 0.5 W x 0.21 D	60	1.05
Cluster antenna + pedestal	0.36 D x 1.8 H + 0.37 D x 0.32 H	84	0.72
Small cell	0.77 H x 0.17 W x 0.15 D	17	0.13
RRU	-	30	0.32

**5.1.11 Design criteria and codes**

For the summary of design criteria requirements, please refer Annex B.

## **MCMC MTSFB TC G026:2020**

### **5.1.12 Site compound**

Site compound of street furniture incorporates attributes required for fast and affordable deployment while at same time blending the pole or equipment cabinets into its surrounding environment. In general, no fencing is required for street furniture and its equipment cabinets, similarly typical roadside cabinets.

### **5.1.13 Earthing and lightning protection**

Earth continuity conductors and earth leads shall be of high-conductivity copper, continuous throughout their whole lengths and without joints, except by means of approved mechanical clamps. Where connections are made at switchgear and such items of electrical equipment, the conductors shall terminate in soldered or compression-type sockets.

If the Mineral-Insulated Mineral Sheathed (MIMS) or Polyvinyl Chloride (PVC) cables are used, the copper outer sheaths of the cables may be utilised as earth continuity conductors. The termination of each cable-run the copper sheaths (or sheaths in the case of single-core, multiple runs of MIMS) or PVC shall be effectively bonded to earth.

Every circuit of a switchboard, distribution board, control board, tap-off unit and splitter switch-fuse unit shall be provided with its own circuit protective conductor. All circuit protective conductors shall be connected to a switch earthing bar before connected to the external earthing network as recommended in ITU-T K.27 and ITU-T K.56.

Performance of earthing system is considered acceptable when the following conditions are met.

- a) On electrical safety, Residual Current Circuit Breaker (RCCB) should trip within 200 ms of test at the RCCB leakage rating. The functionality of RCCB should be verified by RCCB tester in accordance to the Suruhanjaya Tenaga requirement.
- b) To achieve earthing resistance of 10  $\Omega$  is expected, on a best effort basis which there should be a minimum of 3 earth points (using earth rods) to a maximum of 5 earth points at each site

For earthing system, electrodes shall comprise 16 mm diameter, 1.6 m long, extensible-type, copper-steel-cored rods (copper weld or approved equivalent make), driven into the ground at interval of at least twice the driven length of any 2 electrodes. Electrodes shall be driven into ground or similar type electric or pneumatic hammer. Every connection clamp shall be provided with regulation-type concrete inspection chamber and cover.

The minimum number of electrodes installed for each earthing points shall be 2 units and the minimum length of each electrode shall be 1.6 m. The numbers of earthing points indicated in the drawings are indicative only and shall in no way imply that the earthing points are sufficient to obtain the value of 10  $\Omega$ .

A lightning protection air termination or lightning rod shall be fitted to the top of each street furniture, as long as the structure is located nearby buildings which have sufficient lightning protection system. It might not be necessary for the said structure to install its own lightning protection system.

### **5.1.14 Electrical requirement**

Maximum requirement for permanent power supply is 3 phase 60 A, 400 V with solution to tap from the existing power supply available or new application from the power supply provider.

Auto-reclose can be optionally used together with RCCB to avoid nuisance tripping.

Direct Current (DC) and/or Alternating Current (AC) power system should be installed as back up requirements to provide the services to maintain electrical safety.

**5.1.15 Cooling and water protection requirement**

In case of any confine equipment cabinet or camouflage equipment housing solution, sufficient cooling arrangement shall be provided based on heat emission from the equipment. Sufficient water protection shall be provided to prevent water seepage or equipment damage or any electrical short circuit.

**5.2 Aesthetic**

Under special circumstances, some radio stations (especially the radio antennas and microwave dishes) are required to blend in with its surrounding or to be aesthetically pleasing to the sight. This is achieved through various means of treating the main structures inside the station such as the Antenna Mounting Structure (AMS) and/or the equipment enclosure to make them inconspicuous.

The requirements for aesthetic installation, wherever relevant, shall comply with the specification listed in MTSFB 001:2009.

**5.3 Right of Way (RoW)**

In general, Right of Way (RoW) is the legal rights to use and/or pass along a specific route through ground or property belonging to another party, which may be a property owner, e.g. private entity, network facilities provider, public utility provider, local or other authority, for any purposes related to this Technical Code.

As a guide, the property owner should provide a network facilities provider with non-discriminatory access to any street furniture, network facilities or RoW owned by the property owner upon request. The network facilities provider shall pay adequate compensation to the property owner for the access granted.

The property owner may deny any network facilities provider access to the street furniture, network facilities or RoW on a non-discriminatory basis where there is insufficient capacity, or for reason of safety, security, reliability or difficulty of a technical or engineering nature.

This application of RoW shall be read together with other applicable laws.

**6. Technical requirement**

**6.1 Radiocommunications network facilities**

Radiocommunications network facilities installed on any new, existing or replacement structure of street furniture shall comply with the maximum number of equipment and housing size as below.

**6.1.1 Equipment**

The number of equipment installed should be in accordance to Table 6. However, the number of equipment may vary but shall not exceed the total wind resistance area calculated as per Table 5.

**Table 6. Number of equipment**

<b>Equipment descriptions</b>	<b>Equipment dimension (m)</b>	<b>Numbers of equipment</b>
Solid parabolic without radome	0.3	2

## MCMC MTSFB TC G026:2020

Equipment descriptions	Equipment dimension (m)	Numbers of equipment
Flat antenna	2.10 H x 0.5 W x 0.21 D	3
Cluster antenna + pedestal	0.36 D x 1.8 H + 0.37 D x 0.32 H	1
Small cell	0.77 H x 0.17 W x 0.15 D	3
Number of RRU exposed	-	3

### 6.1.2 Equipment cabinet

The dimension of the equipment cabinet shall be in accordance to Table 1.

### 6.1.3 Installation

There are a few types of installation of radiocommunications network facilities on street furniture. The types of installation are as follows.

- a) Type A1: Street lighting pole with equipment cabinet on ground

The example of Type A1 is shown in Figure 1. The requirements for Type A1 installation are described in Figure 2 and Figure 3.

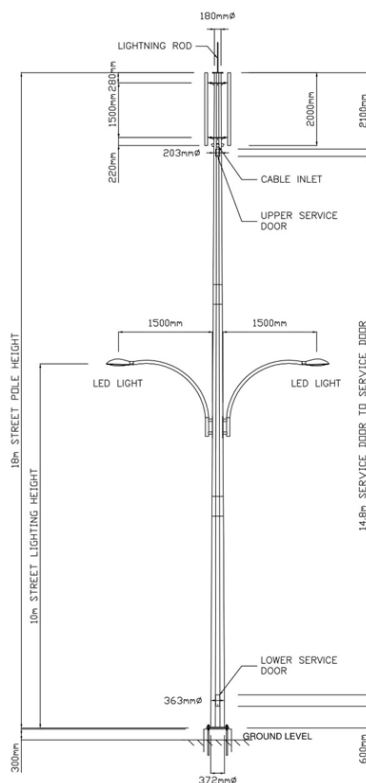

Figure 1: Example of Type A1

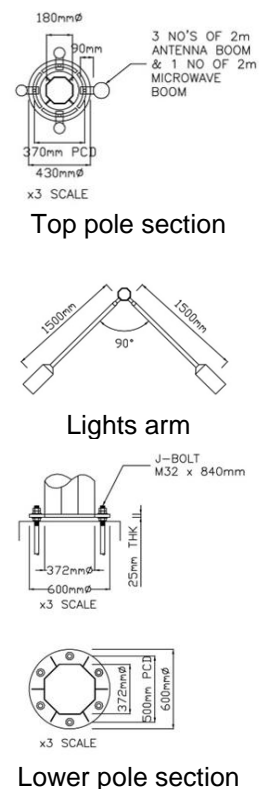

Figure 2: Pole dimension



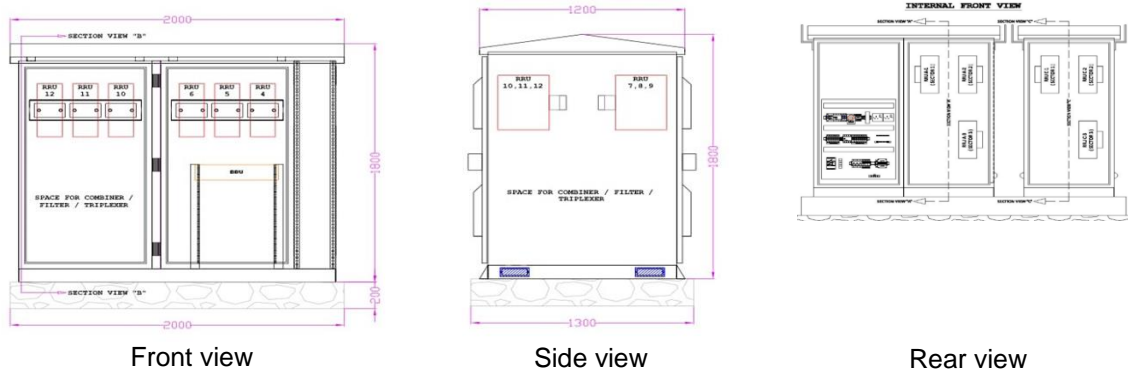

Figure 3. Cabinet dimension

b) Type A2: Street lighting pole with equipment cabinet inside the pole ( $\leq 4$  radio technology)

The example of Type A2 is shown in Figure 4. The requirements for Type A2 installation are described in Figure 5. For Type A2 street lighting pole, the lower diameter shall be 600 mm and the top pole diameter shall be 180 mm.

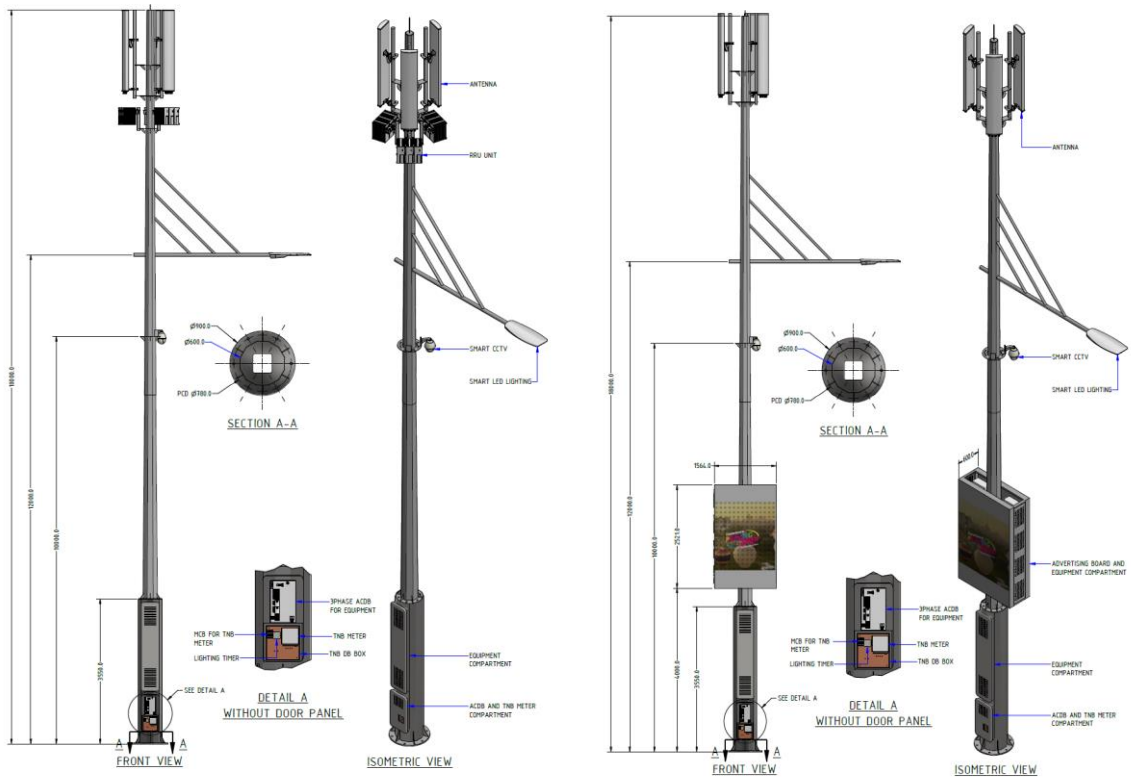
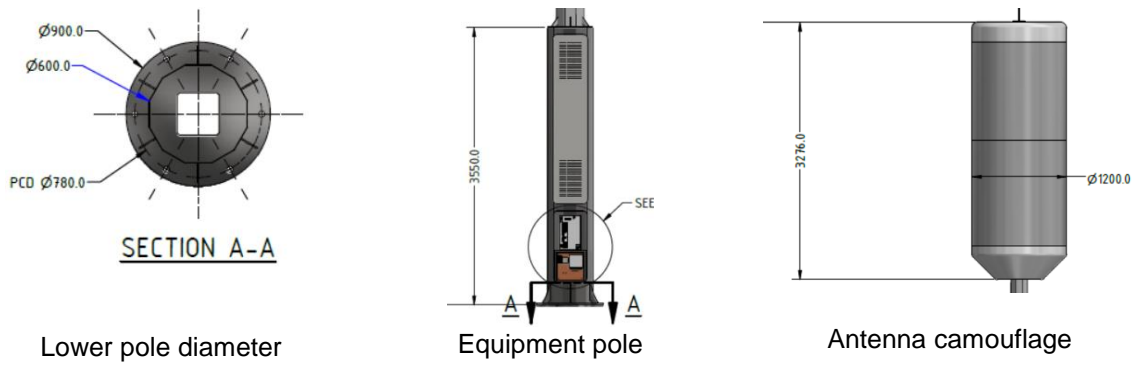

Figure 4. Example of Type A2

**MCMC MTSFB TC G026:2020**



**Figure 5. Type A2 installation requirements**

c) Type A3: Street lighting pole with equipment cabinet mounted on pole

The example of Type A3 is shown in Figure 6. The requirements for Type A3 installation are described in Figure 7.

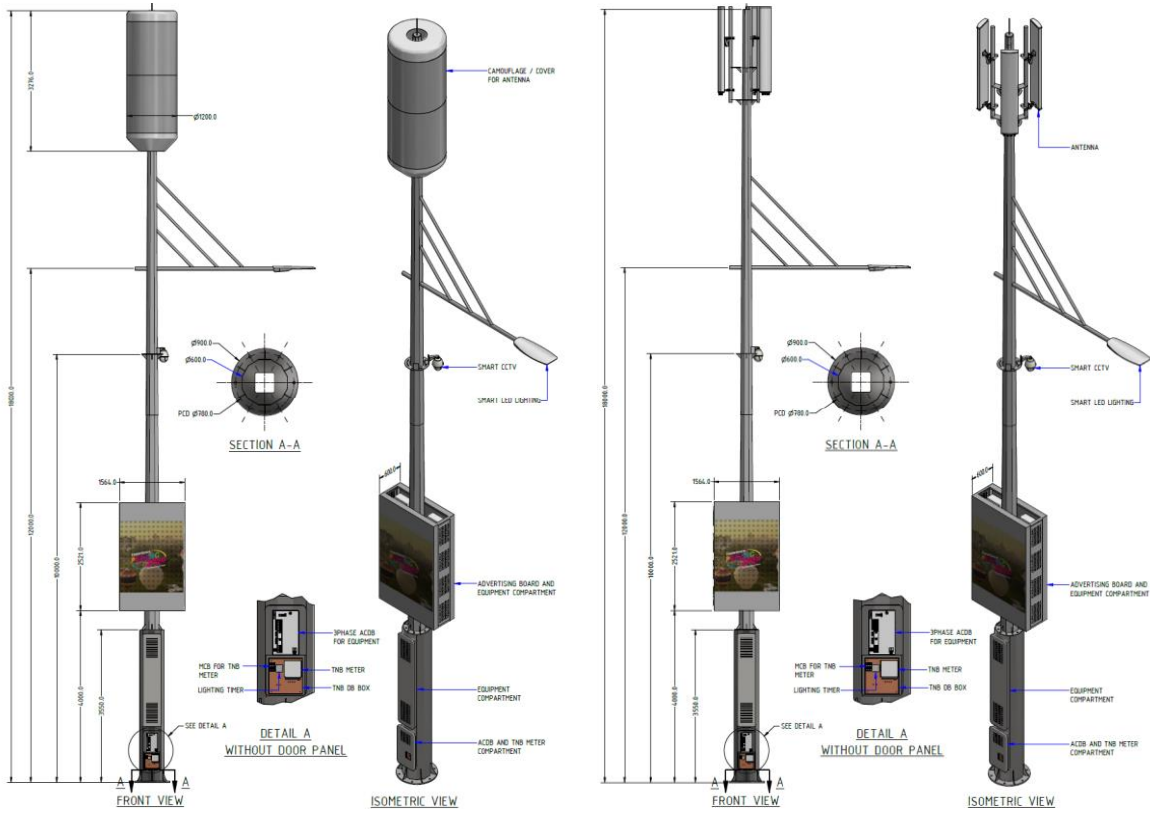

Figure 6. Example of Type A3

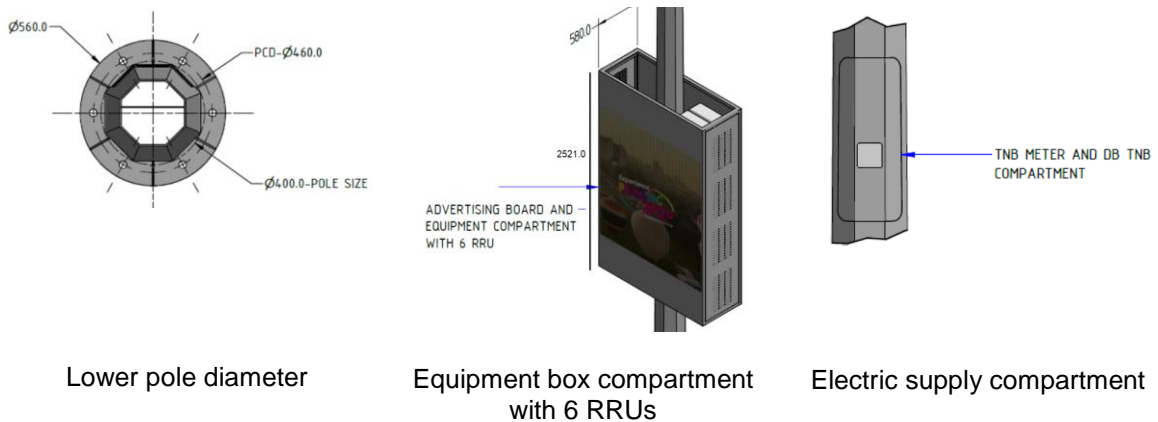

Figure 7. Type A3 installation requirements

**MCMC MTSFB TC G026:2020**

d) Type A4: Street lighting pole with equipment cabinet inside the pole ( $\leq 2$  radio technology)

The example of Type A4 is shown in Figure 8. The requirements for Type A4 installation are described in Figure 9. For Type A4 street lighting pole, the lower diameter shall be 500 mm and the top pole diameter shall be 180 mm.



**Figure 8. Example of Type A4**

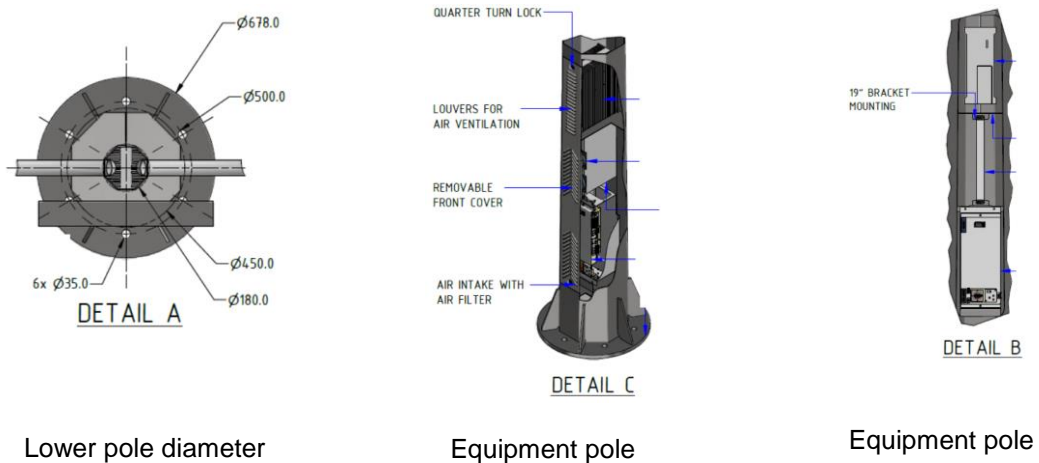

Lower pole diameter

Equipment pole

Equipment pole

**Figure 9. Type A4 installation requirements**

e) Radiocommunications equipment on street road signage and gantry

The examples of installation on street road signage and gantry are as shown in Figure 10.



Examples of installation on gantry

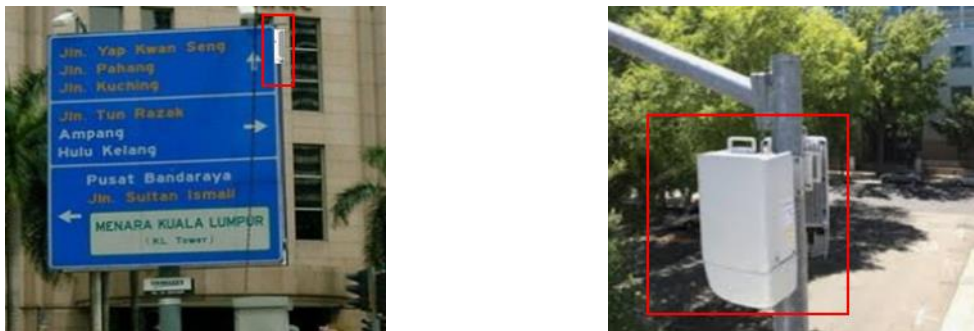

Examples of installation on street road signage

**Figure 10. Examples of installation of equipment on gantry and street road signage**

f) Radiocommunications equipment on street signboard, taxi stand and bus stop

The example of installation on street signboard, taxis stand and bus stop are as shown in Figure 11.



Examples of installation on street signboard

## MCMC MTSFB TC G026:2020



Examples of installation at taxi stand and bus stop

**Figure 11. Examples of radiocommunications equipment on street signboard and bus stop**

### 6.2 Backhaul

Transmission backhaul is inclusive of microwave transmission, fixed line optical fiber or any other wireless backhaul medium.

### 6.3 Operation and maintenance

Maintenance of the radiocommunications network facilities shall be remained under the responsibility of the operator. Regular site inspection is required to ensure the street furniture is structurally sound. This is a preventive maintenance where any deterioration can be highlighted ahead of time and corrective work be done to prevent further degradation to the structure. Failure to observe a regular maintenance schedule can create a potentially hazardous working and operating conditions.

#### 6.3.1 Site access

It is important to ensure that there is 24 hour access availability to the station. However, for highly sensitive area for example 'Sasaran Penting Kerajaan', prior approval shall be obtained for site access. Site access should be made available:

- a) during office hours; and
- b) as and when required at the event of emergency.

Any arrangement on the site access should be commercially agreed by both parties as spelled out in the *Commission Determination on the Mandatory Standard on Access, Determination No.3 of 2016*. The service provider's employees, contractor, vendor and/or agent are responsible to ensure that access members do not violate any service provider's policies, do not perform illegal activities, and do not use the access to property for outside business interests. The service provider's employee(s), contractor, vendor and/or agent bear responsibility for the consequences should the access be misused.

For any other access permission request that the service provider's employees, contractors, vendors and/or agents may deem would lead to the violation of access given, the service provider's employees, contractors, vendors and/or agents shall directly refer to the relevant authorised department or personnel(s) of the service provider for further verification.

Site access shall be strictly controlled. Control will be enforced via the following identification or authentication verification and log record:

- a) the service provider's employee identification document or pass card;
- b) authorisation letter; or
- c) authorised work permit.

Service provider's employee shall not provide their access identification document or pass card, access key and/or access password to anyone, not even service provider's members.

Any personnel(s) that have accessed to the property shall strictly follow the code of conduct as may be outlined while on the property premises.

### **6.3.2 Maintenance activities**

This section seeks to establish procedures and guidelines for the inspection and maintenance of street furniture. It also identifies the deficiencies, the defective items and recommends solutions to keep the structure in good condition and optimum performance.

Structure owner to adhere to maintenance obligations stipulated in paragraph 5.12 of *Commission Determination on the Mandatory Standard on Access, Determination No. 3 of 2016*.

Conditional exemptions can be applied to any unscheduled corrective maintenance in the event of emergency scenario, subject to informing local authority followed by a submission thereafter.

### **6.4 Safety and security**

The contractor shall be responsible and held accountable for all safety and health issues in and around the site.

The contractor shall ensure compliance by its employees, servants, agents and sub-contractors with all applicable laws, provisions, regulations, ordinances, standards and codes of practice now or later in force relating to safety and health, which includes without limitation, the Act 514, *Occupational Safety and Health Act 1994* and the Act 139, *Factory and Machinery Act 1967*. The contractor shall at all times be responsible for ensuring that its employees, servants, agents and sub-contractors perform their duties in a safe, orderly, clean manner and manage safety and health in compliance with the Act 514 and Act 139 and other relevant legal provisions, laws and regulations in force.

The contractor shall provide the purchaser with a copy of its written Safety and Health policy and program prior to commencement of the contract.

The contractor shall at its own expense ensure that all personnel provided in the performance of the works are fully trained, qualified, competent and properly certified in all safety and health aspects. Such training, qualification, competency and/or certification will be provided by the contractor or relevant authorities or bodies under the applicable laws, rules, and regulations, directive of any government body or as required by the purchaser.

The contractor shall ensure that all equipment, machinery, plant, tools, facilities and other items used by the contractor, its employees, servants, agents and subcontractors in the execution of the works shall be at all times of safe, sound, good and working condition, safely and competently operated. The contractor shall at its own expense provide the necessary safety equipment, personnel protective equipment and clothing, footwear, hard hats and such other appliances as may be necessary or required by law or regulation for the proper and safe execution of the works.

The contractor and its subcontractors shall give access to authorised representatives of the authority bodies or any state or local official for the purpose of inspecting or investigating or carrying out any duties under the Act 514 or under any state or local act affecting safety and health.

The contractor shall be responsible for any violation or breach of any safety or health standards, regulation or law on site or relating to the works and shall at its own expense immediately remedy any condition giving rise to such violation or breach. The refusal or inability of the contractor to remedy such violation or breach immediately or within the stated agreed period with the purchaser shall constitute a breach of contract and the purchaser may, in addition to and without prejudice to any other rights, suspend or terminate the contract accordingly.

## **MCMC MTSFB TC G026:2020**

All information and details relating to any accident or incident will be recorded in the site diary and the contractor shall inform the purchaser immediately and further in writing of the accident/incident within 24 hours of its occurrence. For accidents/incidents reportable to statutory bodies, the contractor shall with prior consultation with the purchaser report the accident/incident to the relevant authorities.



**Annex A**  
(normative)

**Normative references**

MTSFB 001:2009, *Technical Standards and Infrastructure Requirements: Radiocommunications Network Infrastructure (External)*.

ITU-T K.27, *Bonding configurations and earthing inside a telecommunication building*

ITU-T K.56, *Protection of radio base stations against lightning discharges*.

ISO 1461, *Hot dip galvanized coatings on fabricated iron and steel articles - Specifications and test methods*

MS 1553, *Code of Practice on Wind Loading for Building Structure*

MS 2112-3, *Electric Cable and Wire - Polyvinyl Chloride (PVC) Insulated Cables of Rated Voltages Up to and Including 450/750 V - Part 3: Non-Sheathed Cables for Fixed Wiring*

MS 2112-4, *Electric Cable and Wire - Polyvinyl Chloride (PVC) Insulated Cables of Rated Voltages Up to and Including 450/750 V - Part 4: Sheathed Cables for Fixed Wiring*

MS IEC 62305, *Protection Against Lightning* (all parts)

BS 499-1, *Welding terms and symbols Part 1: Glossary for welding, brazing and thermal cutting*

BS 3692, *ISO metric precision hexagon bolts, screws and nuts. Specification*

BS 4190, *ISO metric black hexagon bolts, screws and nuts. Specification*

BS 4320, *Specification for metal washers for general engineering purposes. Metric series*

BS 4360, *Specification for weldable structural steels*

BS 4592-2, *Industrial type flooring and stair treads. Expanded metal gratings. Specification*

BS 5493, *Code of practice for protective coating of iron and steel structures against corrosion*.

BS 6399-2, *Loading for buildings. Part 2 Wind loads*

BS 8100, *Lattice towers and masts* (all parts)

BS EN 1011, *Welding. Recommendations for welding of metallic materials*. (all parts)

BS EN 1993-3-1, *Eurocode 3. Design of steel structures. Towers, masts and chimneys. Towers and masts*

BS EN 10210, *Hot finished structural hollow sections of non-alloy and fine grain steels*. (all parts)

BS ISO 5950, *Electrolytic tin-coated cold-reduced carbon steel sheet of commercial and drawing qualities*

BS EN ISO 636, *Welding consumables. Rods, wires and deposits for tungsten inert gas welding of non-alloy and fine-grain steels. Classification*

## **MCMC MTSFB TC G026:2020**

*ANSI/TIA-222-G, Structural Standard for Antenna Supporting Structures and Antennas*

*ASCE Manual 72, Design of Steel Pole Transmission Structures*

*AS 3995, Design of Steel Lattice Towers and Masts*

*Act 514, Occupational Safety and Health Act 1994*

*Act 139, Factory and Machinery Act 1967*

*Determination No.3 of 2016, Commission Determination on the Mandatory Standard on Access*

**Annex B**  
(normative)

**Design criteria and codes**

The summary of the design criteria and codes for street furniture for the installation of radiocommunications network facilities are as shown in Table B.1.

**Table B.1. Design criteria and codes**

No.	Items	Descriptions
1.	Type of structure	Mild steel polygonal street furniture pole.
2.	Height of structure	Maximum 18 m.
3.	Design wind speed	a) 33.33 m/s (120 km/h) 3-second gust wind speed or 22.22 m/s mean hourly wind speed. b) 30 m/s 3-second gust or 20 m/s mean hourly wind speed for the purpose of deflection compliance check.
4.	Partial safety factors in design	a) Appropriate factors correspond to the quality and importance of the street furniture pole shall be obtained from BS 8100. b) A minimum material factor of 1.10 (corresponds to Class A quality) and a minimum wind speed factor of 1.20 (corresponds to site near to main trunk road and railway or any other major public utilities such as reservoir, power transmission lines, residential housing etc) shall be adopted. c) The definition of near shall mean the radial coverage of the height of the pole plus a buffer of 10 m.
5.	Terrain category	a) In the derivation of wind loadings, a terrain category of 3 in accordance with BS 8100 or within town area in accordance with BS 6399-2 shall be used for general design submission. b) In any particular application of the street furniture structure, the relevant terrain characteristic of the particular site shall be used and fresh calculations shall be submitted.
6.	Wind loading	a) Wind loads shall be derived using BS 8100 or ANSI/TIA-222-G may be used if detailed derivation in accordance with Annex C of ANSI/TIA-222-G. b) The building type factor, $K_b$ and the resulting dynamic augmentation factor, $C_r$ , falls within the ANSI/TIA-222-G applicability limit of 0.25. Otherwise, BS 8100 shall be used.
7.	Analysis and derivation of design forces	a) Equivalent static method of analysis may be used. Appropriate wind gust factors and force coefficients for antenna, branches and poles and ancillaries shall be taken into account in deriving the design wind loading. b) For cases whereby the natural frequency of the street furniture being less than 2 Hz, dynamic analysis using spectral analysis or time history analysis shall be carried out to assess the pole response to wind excitation.

**MCMC MTSFB TC G026:2020**

**Table B.1. Design criteria and codes** *(continued)*

No.	Items	Descriptions						
7.	Analysis and derivation of design forces	<p>c) The more critical resulting forces derived from equivalent static method and dynamic method shall be use for detailed design.</p> <p>NOTE: The natural frequency of the street furniture may be calculated using established software, with due consideration of weight and disposition of platform and antenna away from the pole structure centre-line.</p>						
8.	Analysis and design of pole foundation	<p>a) If the subsoil conditions within a depth of twice the maximum base dimension, the footing foundation shall be used. The subsoil conditions dimension is capable to provide a safe bearing capacity of 100 kN/m<sup>2</sup>.</p> <p>b) If the footing foundation not being use, the piled foundation shall be used. There shall be no soil tension being developed at the base of the footing.</p> <p>c) The rotational characteristic of footing onto the pole shall be taken into account when assessing the deflection limit of the pole. A sub grade reaction of 12 000 kN/m<sup>3</sup> may be used for this purpose.</p> <p>d) In no case shall tension be allowed in any piles when a piled foundation is used.</p> <p>e) The minimum factor of safety shall be at least 2 without wind gust effect and 1.5 when wind gust is included for overturning under un-factored design wind speed of 33.5 m/s 3-second wind gust or 22.22 m/s mean hourly wind speed.</p> <p>f) A safety factor 1.05 shall be used if factored wind speed is used with full wind gust effects applied.</p>						
9.	Load configuration	<p>The following items shall be positioned to a maximum of wind resistance:</p> <p>a) 1 unit of 0.3 m diameters parabolic dish and 3 units of flat panel; or</p> <p>b) 1 unit of 0.3 m diameters parabolic dish and 1 unit of cluster antenna.</p>						
10.	Cable configuration	<p>a) 12 units of 0.5 inch RF feeder cable stacked in 1 row and 2 units of 0.25 inch TX cable.</p> <p>b) All cables shall be installed inside the street furniture pole.</p> <p>c) Cable guides shall be placed inside the street furniture pole.</p>						
11.	Street furniture design	Please refer to 5.1.1.						
12.	Material works	<p>All works related to steel, galvanising, welding and bolts and nuts, the contractor shall comply with the following standards;</p> <table border="0" style="width: 100%;"> <tr> <td style="width: 50%;">a) ISO 1461;</td> <td style="width: 50%;">d) BS 4320;</td> </tr> <tr> <td>b) BS 3692;</td> <td>e) BS 4360; and</td> </tr> <tr> <td>c) BS 4190;</td> <td>f) BS EN 1011.</td> </tr> </table>	a) ISO 1461;	d) BS 4320;	b) BS 3692;	e) BS 4360; and	c) BS 4190;	f) BS EN 1011.
a) ISO 1461;	d) BS 4320;							
b) BS 3692;	e) BS 4360; and							
c) BS 4190;	f) BS EN 1011.							
13.	Material strengths	<p>a) All structural steel used are to be as follows:</p> <p>i) grade 43 with a yield strength, <math>f_y = 275</math> N/mm<sup>2</sup>;</p> <p>ii) grade 50 with a yield strength, <math>f_y = 355</math> N/mm<sup>2</sup>; and</p> <p>iii) welded sections with maximum ultimate weld strength of 215 N/mm<sup>2</sup> may be used.</p>						

Table B.1. Design criteria and codes (concluded)

No.	Items	Descriptions
14.	Material strengths	b) If pole sections were being make up of welded pieces, grade 55 with a yield strength, $f_y = 450 \text{ N/mm}^2$ shall not be used unless fatigue analysis in accordance with BS 8100 is carried out. c) All structural bolts used are to be of grade 8.8 with the following properties: i) yield strength $f_y = 627 \text{ N/mm}^2$ ; and ii) shear strength $P_s = 375 \text{ N/mm}^2$ .
15.	Physical characteristics	The maximum tilt of the top structure shall not exceed 1.0 degree from the centre under a design wind speed of 30 m/s 23.33 m/s gust wind speed or 20 m/s 15.56 m/s mean hourly wind speed, which corresponds to 1:20 years return period. Wind gust effects shall be included in the analysis for deflection compliance.
16.	Diameter of pole bottom section	The diameter of pole bottom section are as follows: a) Minimum 400 mm b) Maximum 600 mm
17.	Equipment cabinet dimension	The dimension for equipment cabinet are as follows: a) for cabinet located on ground 1 800 mm (H) x 2 000 mm (W) x 1 300 mm (D) b) for cabinet attached to lighting pole 2 600 mm (H) x 1 600 mm (W) x 580 mm (D) c) for cabinet other than lighting pole 700 mm (H) x 400 (W) x 600 (D)

**Bibliography**

- [1] *The Role of Street Furniture in Expanding Mobile Broadband*, Wireless Infrastructure Association.

## Acknowledgements

### Members of the Radiocommunications Network Facilities (External) Sub-Working Group

Mr Ratnam N A (Chairman)	MEASAT Broadcast Network Systems
Mr Rohaizad Embong (Draft lead)	Celcom Axiata Berhad
Mr Mohamad Norzamir Mat Taib/ Mr Muhaimin Mat Salleh (Secretariat)	Malaysian Technical Standards Forum Bhd
Mr Mohammad Lufhti Manah/ Mr Nor Hisham Eskandar/ Ms Zakiah Nordin	Celcom Axiata Berhad
Ms Shirley Kwok	Digi Telecommunications Sdn Bhd
Mr Emran Kamaruddin/ Ms Irma Syafrida Abd Majid/ Mr Mohamad Yazid Mohamad	edotco Malaysia Sdn Bhd
Mr Barkathul Zaman Bukhari/ Mr Eami Yusry Mohd Yusof/ Mr Mohd Khairil Anuar Mohamed/ Mr Rakuram Gandhi	Maxis Bhd
Mr Mohd Mokhtar Daud	Malaysia Digital Economy Corporation
Mr Leong Yoon Khong / Mr See Boon Leng	Redsun Engineering Sdn Bhd
Mr Ahmad Rifaie Abdul Hamid/ Mr Najib Fadil Mohd Bisri/ Mr Nazar Mohd Nong/ Ms Yuniza Abd Latif	Telekom Malaysia Bhd
Mr Abdulhadi Wahid/ Mr Jacc Goh Kuan Kong/ Mr Khairuddin Harun/ Mr Muhamad Hariz Mohd Fuad/ Mr Saiful Nizar	TIME dotCom Berhad
Mr Amran Abdul Latif/ Mr Norzalee Mohd Rozali	U Mobile Sdn Bhd
Mr Ahmad Faisal/ Mr Muhammad Zharif Anwal/ Ms Ng Yoke Wei/ Mr Noridzwan Abd Rahman/ Mr Rosli Abdullah/ Ms Siti Najwa Muhammad	webe digital sdn bhd
Mr Azmarhisyam Omar/ Ms Thanupriya Vitalingam/ Mr Yap Wei Lim	YTL Communications Sdn Bhd
Mr Kuo Hai Ann	Zettabits Technologies

By invitation:

Mr Meor Faizzudin Meor Shahimudin/  
Mr Mohd Ruzaini Abdul Rahman/  
Ms Nurita Sateri

Dewan Bandaraya Kuala Lumpur

Ms Anis Hanum Hamzah/  
Ir Mohd Khairuul Khair Shah Abdullah Sani/  
Ir Siti Nurilam Mansor

Jabatan Kerja Raya

Ms Nor Malahida Jamiran  
Mr Muhamad Izdihar Sabarudin/  
Ms Ruhsiyah Marjunid

Majlis Bandaraya Melaka Bersejarah  
Majlis Bandaraya Petaling Jaya

Mr Irwan Rizadi Salehapan/  
Mr Noreffendi Parjoh

Majlis Perbandaran Sepang

Mr Muhammad Fadzly Hj Md Yazir  
Ir Marzuki Abdullah

Majlis Perbandaran Seremban  
Perbadanan Putrajaya