

TECHNICAL CODE

FIXED NETWORK FACILITIES - IN-BUILDING AND EXTERNAL

Developed by



Registered by



Registered date:

3 June 2020

© Copyright 2020

MCMC MTSFB TC G024:2020

Development of technical codes

The Communications and Multimedia Act 1998 ('the Act') provides for Technical Standards Forum designated under section 184 of the Act or the Malaysian Communications and Multimedia Commission ('the Commission') to prepare a technical code. The technical code prepared pursuant to section 185 of the Act shall consist of, at least, the requirement for network interoperability and the promotion of safety of network facilities.

Section 96 of the Act also provides for the Commission to determine a technical code in accordance with section 55 of the Act if the technical code is not developed under an applicable provision of the Act and it is unlikely to be developed by the Technical Standards Forum within a reasonable time.

In exercise of the power conferred by section 184 of the Act, the Commission has designated the Malaysian Technical Standards Forum Bhd (MTSFB) as a Technical Standards Forum which is obligated, among others, to prepare the technical code under section 185 of the Act.

A technical code prepared in accordance with section 185 shall not be effective until it is registered by the Commission pursuant to section 95 of the Act.

For further information on the technical code, please contact:

Malaysian Communications and Multimedia Commission (MCMC)

MCMC Tower 1
Jalan Impact
Cyber 6
63000 Cyberjaya
Selangor Darul Ehsan
MALAYSIA

Tel: +60 3 8688 8000
Fax: +60 3 8688 1000
<http://www.mcmc.gov.my>

OR

Malaysian Technical Standards Forum Bhd (MTSFB)

Malaysian Communications & Multimedia Commission (MCMC)
Off Persiaran Multimedia
Jalan Impact
Cyber 6
63000 Cyberjaya
Selangor Darul Ehsan
MALAYSIA

Tel: +60 3 8320 0300
Fax: +60 3 8322 0115
<http://www.mtsfb.org.my>

Contents

	Page
Committee representation.....	iii
Foreword	iv
0. Introduction.....	1
1. Scope	1
2. Normative references	1
3. Abbreviation.....	2
4. Terms and definitions	4
4.1 Broadband.....	4
4.2 Building Management (BM).....	4
4.3 Campus	4
4.4 Concrete kicking block	4
4.5 Fibre Optic Cable (FOC)	4
4.6 Fibre To The Premises (FTTP)	4
4.7 Housing estate	4
4.8 Internet Protocol Television (IPTV)	5
4.9 Multi Dwelling Unit (MDU)	5
4.10 Network Facilities Provider (NFP)	5
4.11 Point-to-Multipoint Fibre (P2MP) FTTP network	5
4.12 Point-to-Point (P2P) FTTP network	6
4.13 Private Property Line (PPL)	6
4.14 Property developer.....	6
4.15 Simple development properties	6
4.16 Single Dwelling Unit (SDU)	7
4.17 Telecommunication Room (TR).....	7
4.18 Voice service.....	7
5. Infrastructure requirements	7
5.1 Building type.....	7
5.2 Fixed network services.....	7
5.3 Infrastructure demarcation	8
5.4 External infrastructure requirement.....	10
5.5 In-building infrastructure requirement	23
6. Cabling requirements	33
6.1 Cable distribution requirement	33
6.2 Cabling for Single-Dwelling Unit (SDU)	34
6.3 Cabling for Multi-Dwelling Unit (MDU)	40

MCMC MTSFB TC G024:2020

6.4	Cabling for campus	47
6.5	CPE cabling design	47
6.6	Cable specification	48
6.7	Labelling and tagging	51
6.8	Testing and commissioning.....	54
6.9	Certification of the material	57
7.	Infrastructure and cabling acceptance procedure	57
8.	Safety and precaution	58
8.1	Configuration of safety device.....	58
8.2	Other safety elements	59
Annex A Fibre Termination Box (FTB) specifications		60
Annex B Specification for in-building fibre cable		62
Annex C Specification for blown fibre - alternative in-building fibre cabling system		64
Annex D Micro duct		66
Annex E Sample of core assignment		67

Committee representation

This technical code was developed by Fixed Network Facilities Sub Working Group under the Network and Broadcast Infrastructure and Facilities Working Group of the Malaysian Technical Standards Forum Bhd (MTSFB) which consists of representatives from the following organisations:

Core MTX Sdn Bhd

Digi Telecommunications Sdn Bhd

edotco Group Sdn Bhd

Malaysian Digital Economy Corporation

Maxis Bhd

Redsun Engineering Sdn Bhd

Telekom Malaysia Berhad

TIME dotcom Bhd

U Mobile Sdn Bhd

Universiti Teknikal Malaysia

MCMC MTSFB TC G024:2020

Foreword

This technical code for Fixed Network Facilities - In-building and External ('this Technical Code') was developed pursuant to section 185 of the Act 588 by the Malaysian Technical Standards Forum Bhd (MTSFB) via its Fixed Network Facilities Sub Working Group under the Network and Broadcast Infrastructure and Facilities Working Group.

This Technical Code shall replace the following Technical Codes:

- a) MTSFB 008:2005, *Technical Standard and Infrastructure Requirement (TSIR) - Part 1: Fixed Network Infrastructure (Revision 1)*;
- b) MCMC MTSFB TC G006:2016, *Technical Standard and Infrastructure Requirements (TSIR) - Fixed Network Infrastructure for Simple Development Properties*; and
- c) MCMC MTSFB TC G007:2016, *Technical Standard of In-building Fibre Cabling for Fibre-To-The-Premise (First Revision)*.

The above Technical Codes shall be deemed to be invalid to the extent of any conflict with this Technical Code.

This Technical Code shall continue to be valid and effective from the date of its registration until it is replaced or revoked.

FIXED NETWORK FACILITIES - IN-BUILDING AND EXTERNAL

0. Introduction

An access network is a type of communications network which connects subscribers to their immediate service provider. Access network should also support Point-To-Point (P2P) technologies such as Ethernet, which bypasses any outside plant splitter. The process of communicating with a network begins with an access attempt, in which one or more users interact with a communications system to enable initiation of user information transfer. An access attempt itself begins with an issuance of an access request by an access originator.

This Technical Code is intended as a reference for architects, consulting engineers, owners, property developers and others who are responsible for planning and erecting buildings. This is in line with the objective to meet the requirements of end users for fixed communications services with minimum disruptions to all services offered by the service providers.

1. Scope

This Technical Code specifies the requirements for in-building and external fixed network facilities for Single Dwelling Unit (SDU), Multi-Dwelling Unit (MDU) and campus type.

Fixed network facilities include all infrastructure and cabling required for fixed network services.

2. Normative references

The following normative references are indispensable for the application of this Technical Code. For dated references, only the edition cited applies. For undated references, the latest edition of the normative references (including any amendments) applies.

MCMC MTSFB TC G025-1:2020, *Basic Civil Works - Part 1: General Requirements*

MCMC MTSFB TC G025-2:2020, *Basic Civil Works - Part 2: Open Trench*

ITU-T G.652.D, *Characteristics of a single-mode optical fibre and cable*

ITU-T G.657.A, *Characteristics of a bending-loss insensitive single-mode optical fibre and cable*

ITU-T L.103, *Optical fibre cables - Cable structure and characteristics*

IEC 60364-1, *Low-voltage electrical installations - Part 1: Fundamental principles, assessment of general characteristics, definitions*

IEC 60529, *Degrees of protection provided by enclosures (IP Code)*

IEC 60794-2, *Optical fibre cables - Part 2: Indoor cables - Sectional specification*

IEC 60825-1, *Safety of laser products - Part 1: Equipment classification and requirements*

ISO 2081, *Metallic and other inorganic coatings - Electroplated coatings of zinc with supplementary treatments on iron or steel*

BS 1363-1, *13 A plugs, socket-outlets, adaptors and connection units. Specification for rewirable and non-rewirable 13 A fused plugs*

MCMC MTSFB TC G024:2020

BS 6500, *Electric cables. Flexible cords rated up to 300/500 V, for use with appliances and equipment intended for domestic, office and similar environments*

BS EN 6651, *Protection against lightning (all parts)*

BS EN 50075, *Specification for flat non-wirable two-pole plugs 2.5 A 250 V, with cord, for the connection of class II-equipment for household and similar purposes*

EIA/TIA 568, *Commercial Building Telecommunications Cabling Standard*

ICEA S-104-696, *Indoor-Outdoor Optical Fiber Cable*

Telcordia GR-3159, *Generic Requirements for Fiber-Reinforced Composite (FRC), Concrete, and Steel Utility Poles*

3. Abbreviation

For the purposes of this Technical Code, the following abbreviations apply.

AC	Alternating Current
ACPDB	AC Power Distribution Board
ARS	Automatic Restoration System
BM	Building Management
BTU	Broadband Termination Unit
CAT3	Category 3
CAT5	Category 5
CAT5e	Category 5 Enhance
CO	Central Office
CPE	Customer Premise Equipment
DB	Distribution Box
DC	Direct Current
DP	Distribution Point
DSL	Digital Subscriber Line
ELCB	Earth Leakage Circuit Breaker
ELR	Earth Leakage Relay
ELV	Extra Light Voltage
FA-SC	Field Assembly Standard Connector
FOC	Fibre Optic Cable
FOTS	Fibre Optic Trunking System
FRP	Fibre Reinforced Plastic
FTB	Fibre Termination Box
FTTP	Fibre To The Premises

FWS	Fibre Wall Socket
GI	Galvanised Iron
HDPE	High-Density Polyethylene
IPTV	Internet Protocol Television
JMB	Joint Management Building
LAN	Local Area Network
LZSH	Low Smoke Zero Halogen
MCB	Main Circuit Breaker
MDU	Multi-Dwelling Unit
MSC	Multimedia Super Corridor
NFP	Network Facilities Provider
OLTS	Optical Loss Test Set
ONU	Optical Network Unit
OSHE	Occupational Safety, Health and Environment
OTDR	Optical Time Domain Reflectometer
P2MP	Point-to-Multipoint Fibre
P2P	Point-To-Point
PON	Passive Optical Network
PPL	Private Property Line
PSTN	Public Switched Telephone Network
PVC	Polyvinyl Chloride
RJ11	Registered Jacket type 11
RJ45	Registered Jacket type 45
SC/APC	Standard Connector/Angle Polished Connector
SC/UPC	Standard Connector/Ultra Polished Connector
SDU	Single Dwelling Unit
SOC	Splice on Connector
TO	Telecommunication Outlet
TPN	Three Phase and Neutral
TR	Telecommunication Room
U/G	Underground
uPVC	Unplasticised Polyvinyl Chloride
VOD	Video-On-Demand
VoIP	Voice over Internet Protocol

MCMC MTSFB TC G024:2020

4. Terms and definitions

For the purposes of this Technical Code, the following terms and definitions apply.

4.1 Broadband

High-speed internet access where data, e-mail, videos, music and other applications can be downloaded at speeds significantly faster than those available through dial-up modems.

4.2 Building Management (BM)

The entity responsible to maintain the infrastructure provided within Private Property Line (PPL) is in good condition. It may include an individual premises owner or a Joint Management Body (JMB).

4.3 Campus

A combination of SDU and/or MDU located within the same compound with single or multiple Telecommunication Room (TR). Examples of campus property type are as follows:

- a) school;
- b) university;
- c) hospital;
- d) public transportation facilities (e.g. bus station and airport);
- e) shopping complex; and
- f) port.

4.4 Concrete kicking block

Kicking block is a pole accessory to prevent the pole from slanting on sandy/soft soil environment, and it is designed for outdoor use in area with high humidity and heavy rainfall. The kicking block is designed to tie to pole by using a u-bolt and nuts.

4.5 Fibre Optic Cable (FOC)

Fibre Optic Cable (FOC) is a high-speed data transmission medium. Fibre is the future proof technology which has the ability to accommodate any new technologies and applications that require higher bandwidth with much lower maintenance and operational cost than the legacy technologies.

4.6 Fibre To The Premises (FTTP)

Fibre To The Premises (FTTP) is a generic term of providing fixed network services via FOC from NFP Central Office (CO) direct to end user premises. FTTP is an enhancement of legacy technologies using a metal cable network via Public Switched Telephone Network (PSTN) or Digital Subscriber Line (DSL) technology.

4.7 Housing estate

Housing estate is a group of houses and other buildings built together as a single development. A housing estate is usually built by a property developer and controlled by one management. It may consist of residential and/or business, SDU and MDU type of properties.

4.8 Internet Protocol Television (IPTV)

Internet Protocol Television (IPTV) is a protocol which delivers the contents using the internet suite over a packet-switched network such as a Local Area Network (LAN) or the internet, instead of being delivered through traditional terrestrial, satellite signal, and cable television formats.

4.9 Multi Dwelling Unit (MDU)

MDU generally refers to building constructed with more than 6 stories and generally equipped with TR. Examples of MDU are as follows:

- a) high rise residential (e.g. condominium and apartment);
- b) office building;
- c) commercial building; and
- d) complex.

4.10 Network Facilities Provider (NFP)

The owners/providers of network facilities licensed under the CMA 1998.

4.11 Point-to-Multipoint Fibre (P2MP) FTTP network

A fibre network technology known as Passive Optical Network (PON) with a single FOC core from CO. It can be split into a few single FOC core to serve multiple users as shown in Figure 1.

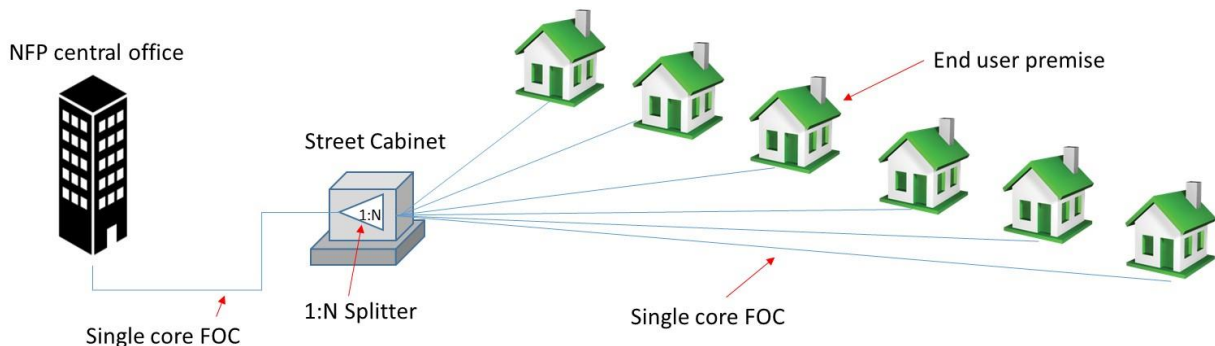

Figure 1. Point-to-Multipoint Fibre (P2MP) network design

MCMC MTSFB TC G024:2020

4.12 Point-to-Point (P2P) FTTP network

A fibre network technology known as Passive Optical Network (PON) with a dedicated FOC core between CO and end users as shown in Figure 2.

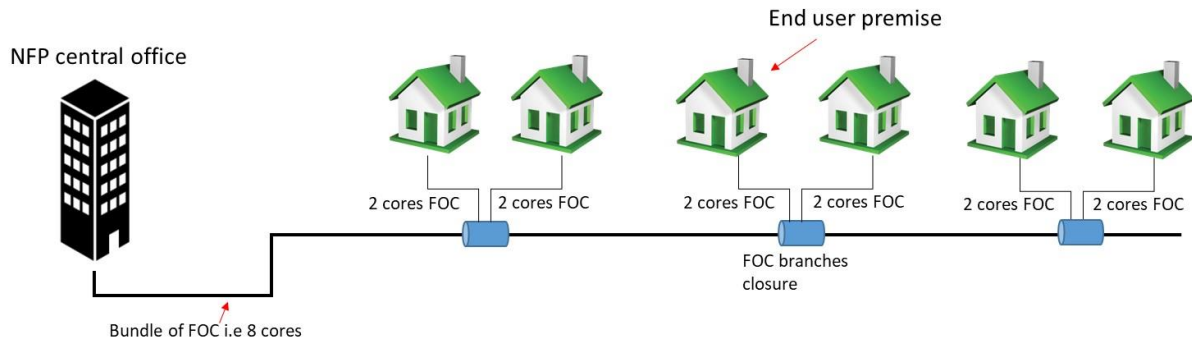

Figure 2. P2P fibre network design

4.13 Private Property Line (PPL)

A legal property development boundary as permitted by the authorities. Fence, drain, road and wall could be examples of boundary which shall clearly separate between public or other personal and private areas which are under the property developer's responsibility. The property developer shall be responsible to all communications infrastructure within the PPL.

4.14 Property developer

A company and individual, a partnership, a co-operative society, a body of person who or which engages in or carries on or undertake or causes to be undertaken property development.

4.15 Simple development properties

The commercial or public amenities property with less than 2 acres of land size and the building built-up is not more than 1 acre (1 acre is 4 046.9 m²). Distance of property developer's premises access manhole or pole from NFP's infrastructure is within 150 m. Subscribed service is limited to 10 telephone lines or/and 1 broadband only. Example of the properties are as listed below:

- a) warehouse;
- b) factory;
- c) petrol station;
- d) single outlet shop or restaurant;
- e) showroom;
- f) community hall;
- g) worship house; and
- h) guard house.

4.16 Single Dwelling Unit (SDU)

A landed property or building with less than 6 stories which is generally not equipped with TR. Example of SDU are as follows:

- a) terrace houses;
- b) bungalows; and
- c) shop lots.

4.17 Telecommunication Room (TR)

A dedicated room with a security lock to locate all fixed network equipment and cables.

4.18 Voice service

Communication of sound over a distance using wire or wireless telephones. Voice service may be offered via analogue signal or Voice Over Internet Protocol (VoIP).

5. Infrastructure requirements

5.1 Building type

There are several categories of buildings that can be categorised as shown in Table 1 below.

Table 1. Categories of building

SDU	MDU	Campus
Bungalow	Condominium or apartment	Combination of SDU and MDU (e.g. university, hospital, complex, school)
Semi-detached		
Terrace single storey		
Terrace double storey		
Office building or shop house less than 6 floors	Office building or shop house more than or equal to 6 floors	Public transport facilities (e.g. airport, bus station, railway station, jetty)
Industrial or commercial lot	N/A	Shopping complex
Simple development	N/A	Amusement park

5.2 Fixed network services

The minimum services, also called as essential communications services, that shall be supported by a fixed network facility are voice and broadband.

Typical connection between NFP network and customer premises is as shown in Figure 3.

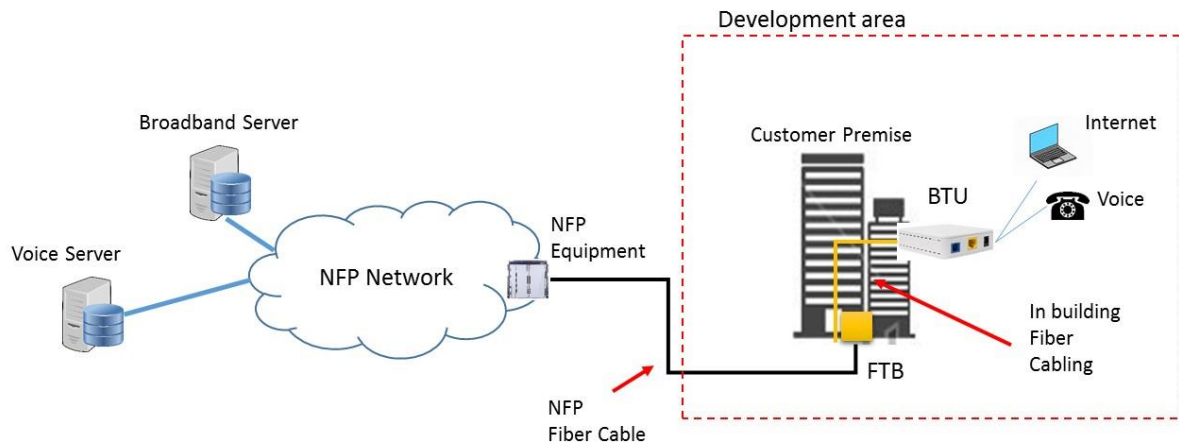

Figure 3. Typical network connection between NFP network and customer premises

5.3 Infrastructure demarcation

The infrastructure boundary demarcation point between a property developer and NFP is the PPL. The infrastructure inside the PPL shall be provided by property developer. The ownership and responsibility of the infrastructure within the PPL shall be handed over to the BM, JMB or premises owner as the case may be.

Link-up access infrastructure is recommended to be prepared by property developer to ensure smooth service provision. However, it can be discussed with NFP through commercial arrangement on the best option.

The demarcation and responsibility of NFP, property developer, BM, JMB and premises owner can be divided into 2 phases which are:

- a) Phase 1 - During development; and
- b) Phase 2 - Post development.

5.3.1 Phase 1 - During development

The infrastructure inside the PPL for SDU shall be provided by property developer during the development phase as illustrated in Figure 4 below. The property developer shall be responsible to ensure all required infrastructure and facilities to support fixed network services are provided.

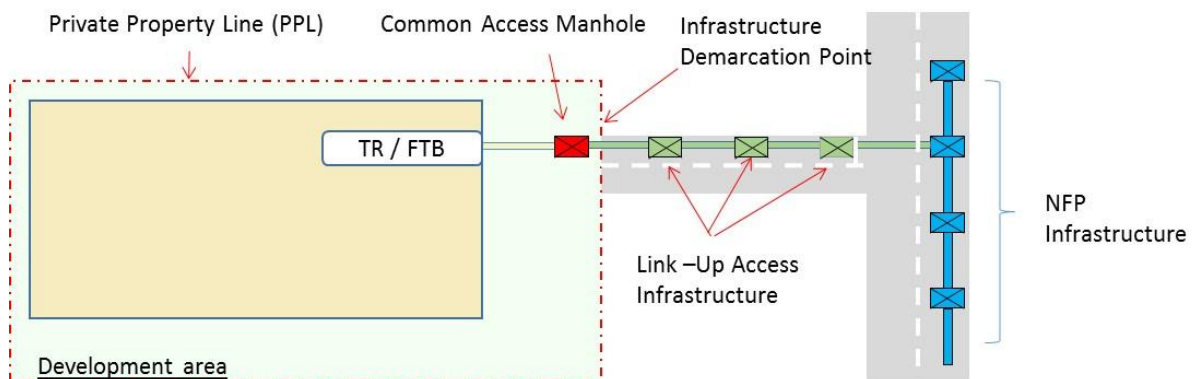

Figure 4. SDU infrastructure demarcation point

The ownership of the infrastructure inside the PPL will be handed over to BM, JMB or premises owner, as the case may be, after completion of the development phase

A proper handover agreement shall be carried out between property developer and NFP upon completion of the construction.

The infrastructure inside the PPL of MDU shall be provided by property developer during the development phase as illustrated in Figure 5.

A proper handover agreement shall be carried out between property developer and NFP upon completion of the construction.

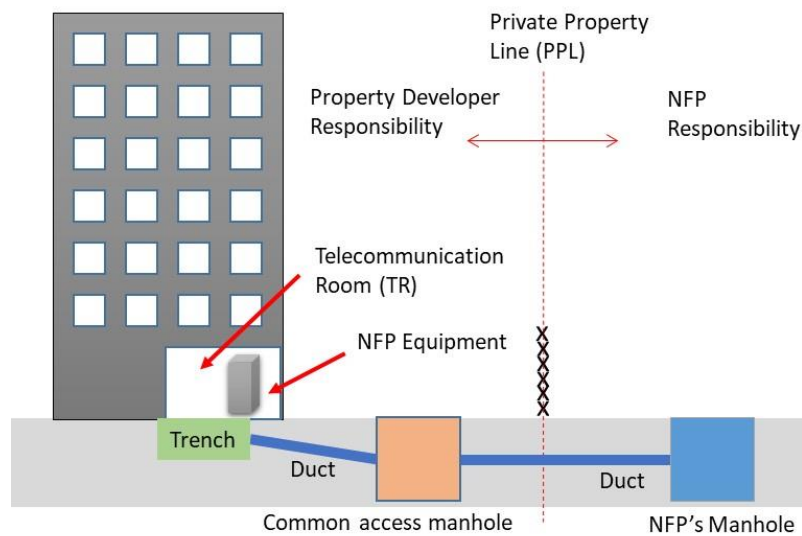

Figure 5. MDU Infrastructure demarcation point

The infrastructure inside the PPL of housing estate and campus type shall be provided by property developer during the development phase as illustrated in Figure 6. A proper handover agreement shall be carried out between property developer and NFP upon completion of the construction.

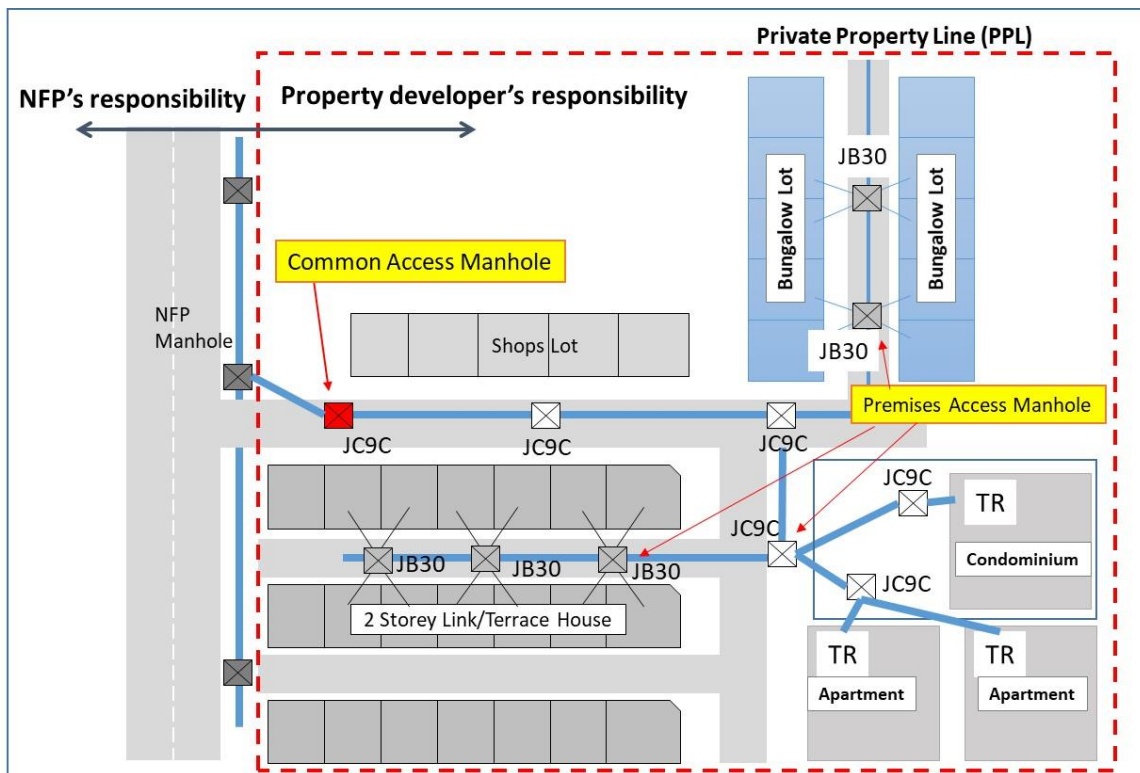

Figure 6. Housing estate and campus type infrastructure demarcation

5.3.2 Phase 2 - Post development: Premises Owner, BM or JMB and NFP

For SDU, premises owner shall be responsible to maintain all the infrastructure inside the PPL to ensure it is in good working condition.

For MDU, property developer shall handover the infrastructure inside the PPL to BM or JMB that will be responsible to manage the infrastructure. BM or JMB is responsible to maintain all the infrastructure to ensure it is in good working condition.

For campus type development, a property developer may handover the infrastructure inside the PPL to selected NFP with the proper handover agreement. NFP shall ensure the infrastructure is always in good condition to ensure a smooth service provision to the end-users. Other parties who wish to utilise any of the infrastructure within the PPL are required to notify and obtain permission from the selected NFP.

5.4 External infrastructure requirement

5.4.1 Underground infrastructure

The requirements of underground infrastructure shall follow as below. Detailed specifications of trenching method and requirement as specified in MCMC MTSFB TC G025-1:2020 and MCMC MTSFB TC G025-2:2020.

5.4.1.1 Manhole

Manhole shall be installed with particular attention as below:

- a) minimum hazards to traffic and personnel;

- b) easily accessible at any time;
- c) not to be covered by any obstacle or landscape; and
- d) adequate size to accommodate all equipment including repeater housings and cable joints.

The sectional length from a manhole centre to the next manhole centre shall be within 80 m to 150 m. The manhole shall be able to sustain up to 20 years.

For manhole located on the main road, it is highly recommended to apply anti-theft feature such as installing double layer manhole cover to protect the system from thefts.

Property developer shall consult NFP on the appropriate selection of the location and size of the manhole to be constructed. The recommended manhole size, number of duct ways and location are shown in Table 2.

Table 2. Manhole size and location

No	Type of manhole	Recommended size (mm) (L x W x D)	No. of duct way	No. of premise linked duct way	No of premise	Location or criteria
1	JB30	850 x 850 x 650	2	4	< 4	a) Last connection to premises units. b) Premises access manhole.
2	JRC7	1,160 x 855 x 850	2	N/A	< 72	a) On small roadside to link up with JB30. b) Common access manhole. c) TR linked manhole.
3	JC9C	1,960 x 1,260 x 1,020	4	N/A	> 576	a) On heavy roadside to link up with JB30/JRC7. b) Common access manhole. c) TR linked manhole.
4	R1A	2,200 x 1,615 x 1,680	6 or 8	N/A	< 576	TR linked manhole.

The samples of manhole types, manhole locations and number of duct ways in a development area are shown in Figure 7.

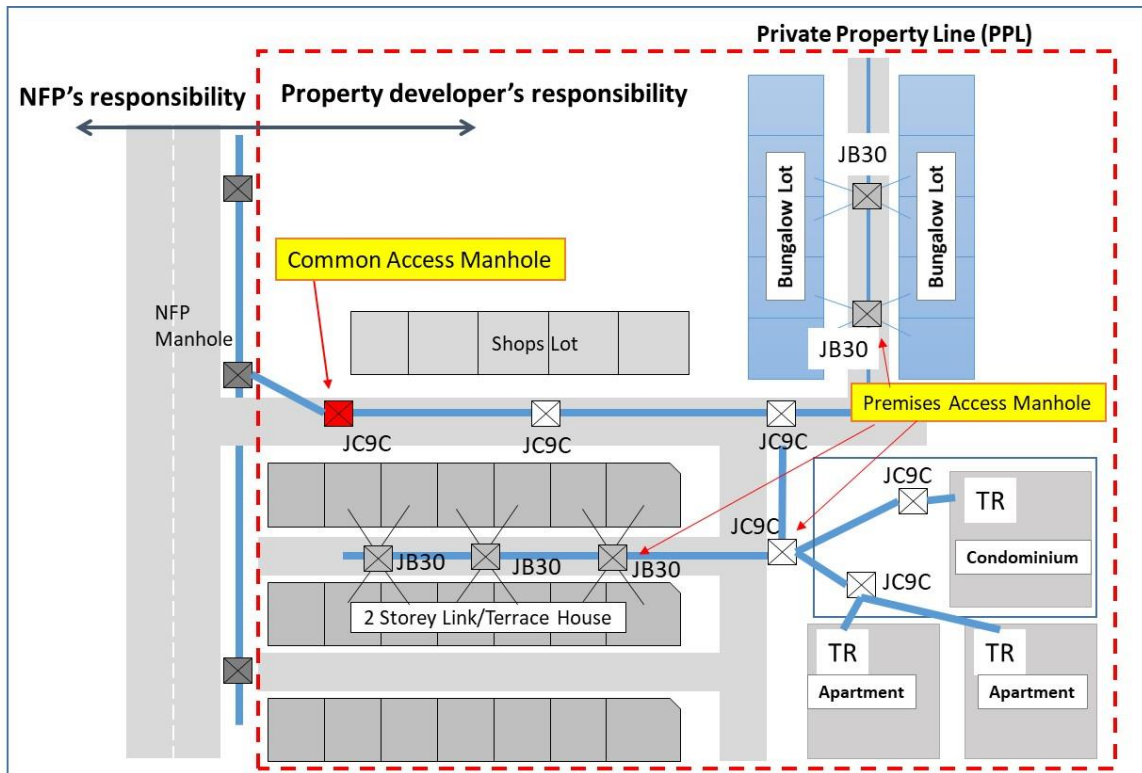

Figure 7. Manhole types and locations

5.4.1.1.1 Common access manhole

Common access manhole is the property developer's last manhole which is linked to NFP's manhole. All connections from NFP network into the development area within PPL shall pass through the common access manhole. There could be more than one common access manholes depending on the underground ducting design and number of NFP connections to the development area.

Property developer shall provide separate ducts from the common access manhole to every NFP's manhole, otherwise a separate common access manhole shall be provided for every NFP in case of multiple NFPs are required to provide the services.

For residential area, minimum of JRC7 manhole size with 2 duct ways shall be provided. For a business area with a large amount of property, minimum of JC9C common access manhole size with 4 duct ways shall be provided. The property developer should consult with the NFP for the appropriate size.

5.4.1.1.2 Premises access manhole

The premises access manhole is a manhole connecting the premises with the underground ducting. Premises access manhole can be a dedicated manhole to every premises or shared by multiple premises as illustrated in Figure 7.

The premises access manhole shall be at least JB30 for SDU and JC9C for MDU with heavy-duty cover.

5.4.1.2 Underground duct

The duct size for connecting premises access manhole to bungalow, linked house or similar type of properties shall be at least 40 mm in diameter. The duct size for connecting premises access manholes to other MDU, high rise SDU and all commercial properties shall be 100 mm to 110 mm in diameter.

MCMC MTSFB TC G024:2020

The duct material shall be made from Polyvinyl Chloride (PVC) or harder material with minimum thickness of 2.0 mm. For road crossing, the minimum class B or equivalent Galvanised Iron (GI) pipe shall be used.

Each duct or subduct shall be installed with a pull string or draw rope for cable installation.

The duct is recommended to be installed with sub-ducts. The specification of the sub-ducts shall be as follows:

- a) 3 High-Density Polyethylene (HDPE) sub-ducts with 40 mm in diameter; or
- b) 5 HDPE sub-ducts with 32 mm in diameter.

The number of duct-ways shall depend on the forecast requirement of the premises for a period of 20 years. Property developer should consult NFP on the appropriate design and number of duct-ways.

The property developer shall ensure that the constructed ducting system has minimal risks from natural disasters such as flood, landslides and etc. The property developer shall ensure the ducting system is always in a good working condition.

The duct routes shall be as straight as possible without sharp bends. The bending radius shall not be less than 10 times of duct diameter as shown in Figure 8.

The installation of underground ducts shall be according to MCMC MTSFB TC G025-1:2020.

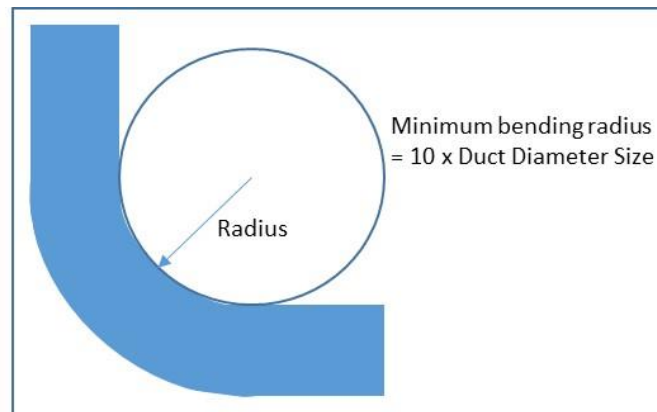

Figure 8. Duct bending radius

5.4.1.2.1 Concrete encasement

For 4 duct ways and above, the duct shall be encased in concrete with the minimum mixer ratio of cement, sand and aggregate of 1:4:3. The specifications shall be as illustrated in Figure 9.

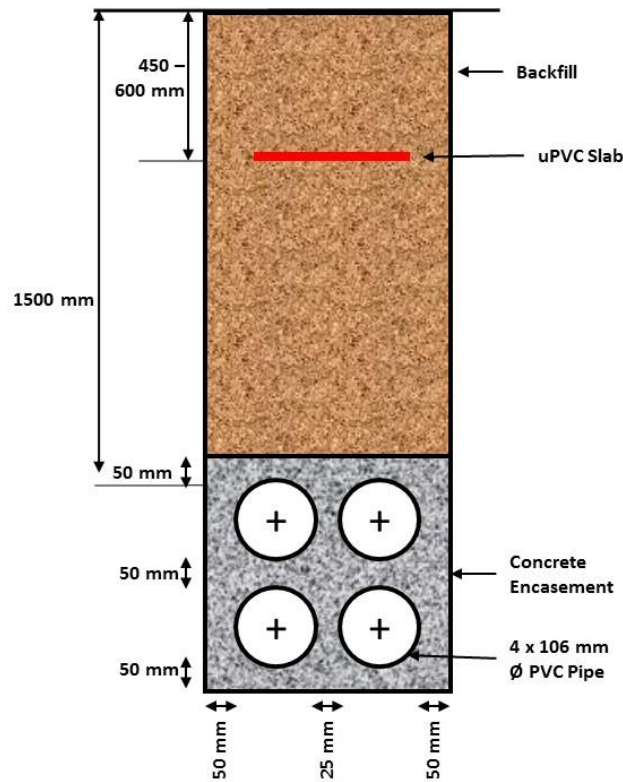

Figure 9. Duct depth specification

5.4.1.2.2 Unplasticised Polyvinyl Chloride (uPVC) slab

Unplasticised Polyvinyl Chloride (uPVC) slab shall be installed with the minimum depth of 440 mm from the ground surface as a warning indication as illustrated in Figure 9.

5.4.1.2.3 Duct and cable arrangement

The arrangement of ducts and cables shall be according to Figure 10 below. The lowest duct on the bottom left shall be used first and continue to the right. The allocation and duct space shall be managed by the BM or selected NFP.

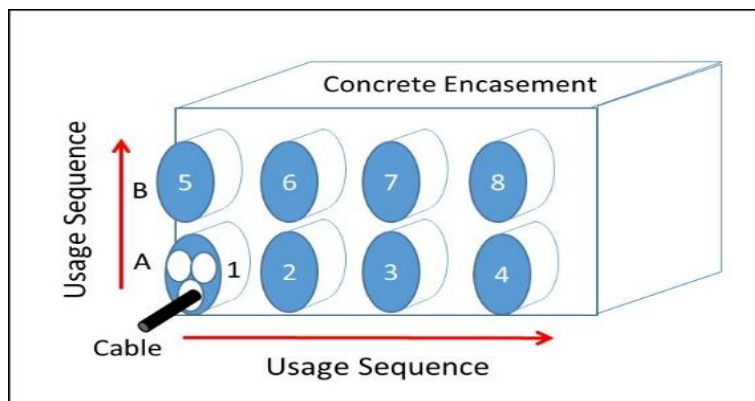

Figure 10. Ducts and cables arrangement for underground

5.4.1.2.4 Ducting crossing the drain

For ducting crossing the drain, the construction shall be according to Figure 11 or Figure 12 depending on the drain depth.

If the drain depth is more than 450 mm (1.5 ft), the duct may be installed through the drain by using GI pipe with a minimum diameter of 100 mm to protect from damages. The GI pipe shall be placed in such a way to avoid trapping of garbage and water blockage.

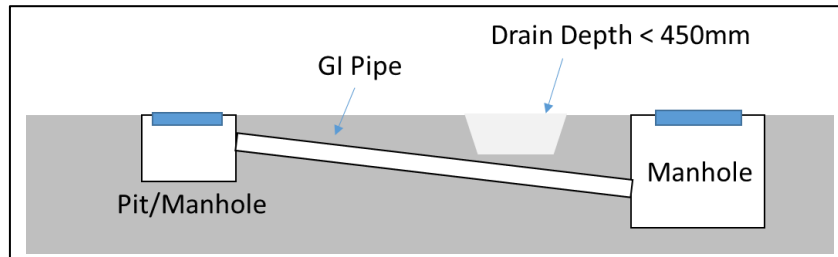

Figure 11. Ducting installation under the drain

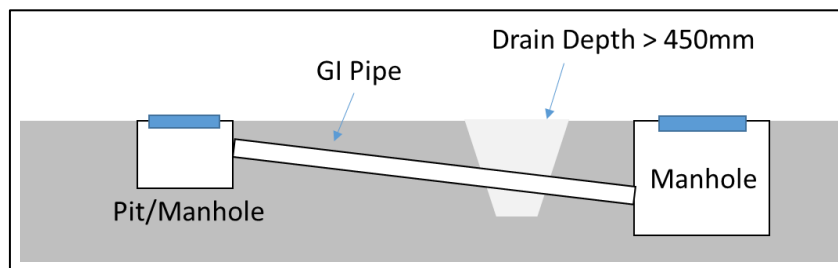

Figure 12. Ducting installation through the drain

5.4.1.3 Access to premises

5.4.1.3.1 Connection to SDU premises

Dedicated ducting shall be prepared for each connection from premises access manhole to each premises. Sharing of the duct for multiple premises is not allowed. The location of premises access manhole can either be at premises back lane or in front of the premises.

Before entering the wall section of the premises, a small pit with a minimum size of 300 mm x 300 mm x 300 mm shall be prepared for easy access during the maintenance work. The FTB shall be placed outside of the wall at 2 m height for easy future operation and maintenance. The details are as illustrated in Figure 13. Each duct shall be installed with a pull string or draw rope for easier drop cable installation.

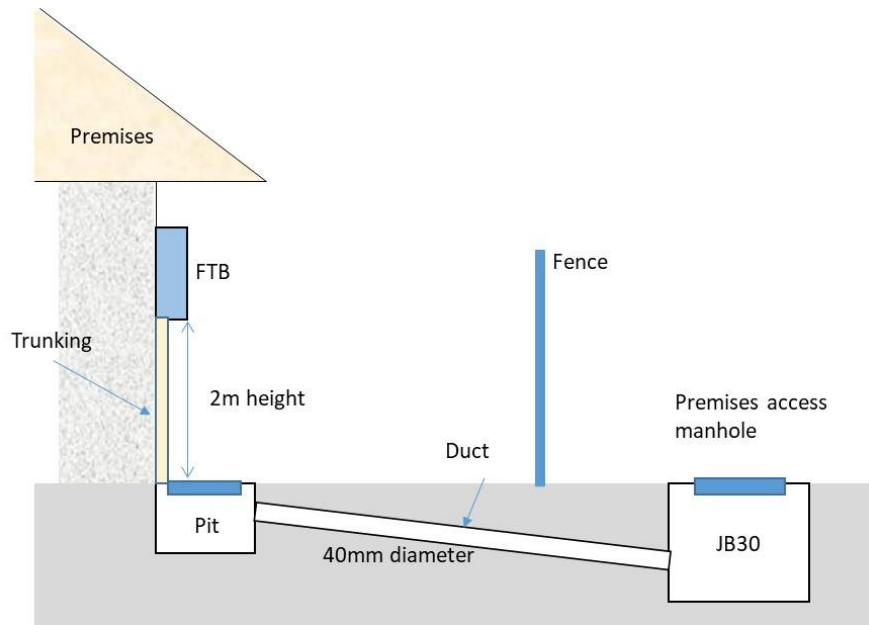

Figure 13. Access to SDU premises

. The duct route shall not be installed inside individual premises compound as shown in Figure 14.

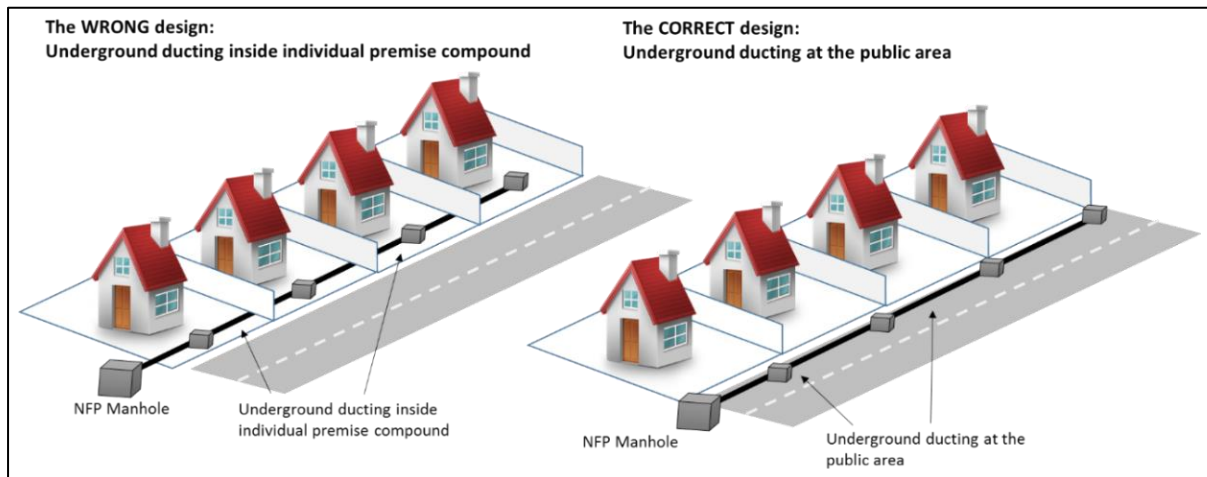

Figure 14. Duct route for premises compound

The installation of ducts to each premises of SDU shall be as shown in Figure 15. Every premises shall be prepared with a dedicated premises access duct from the nearest manhole.

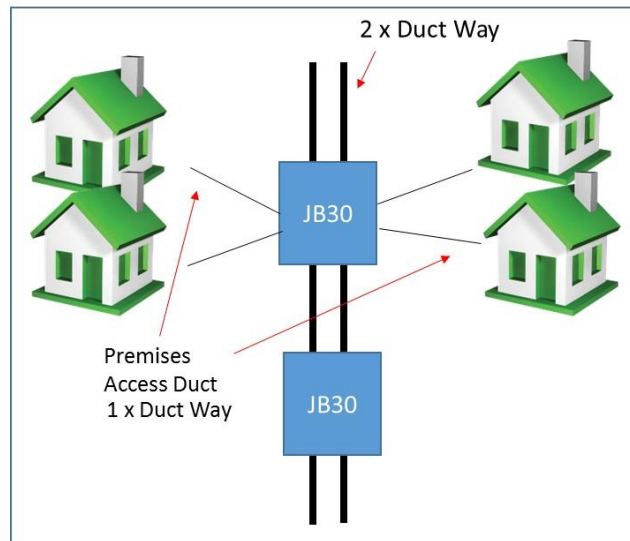

Figure 15. Duct way connection for SDU

5.4.1.3.2 Connection to Multi-Dwelling Unit (MDU) premises

Minimum of 2 ways ducting shall be prepared for connection from premises access manhole to the building as illustrated in Figure 16. Each duct shall be installed with a pull string or draw rope for easier drop cable installation.

A pit with size 600 mm (W) x 600 mm (D) x 600 mm (H) shall be prepared before entering the TR of the building.

Wall mounted or rack type of FTB shall be placed inside the TR depending of the capacity of the building.

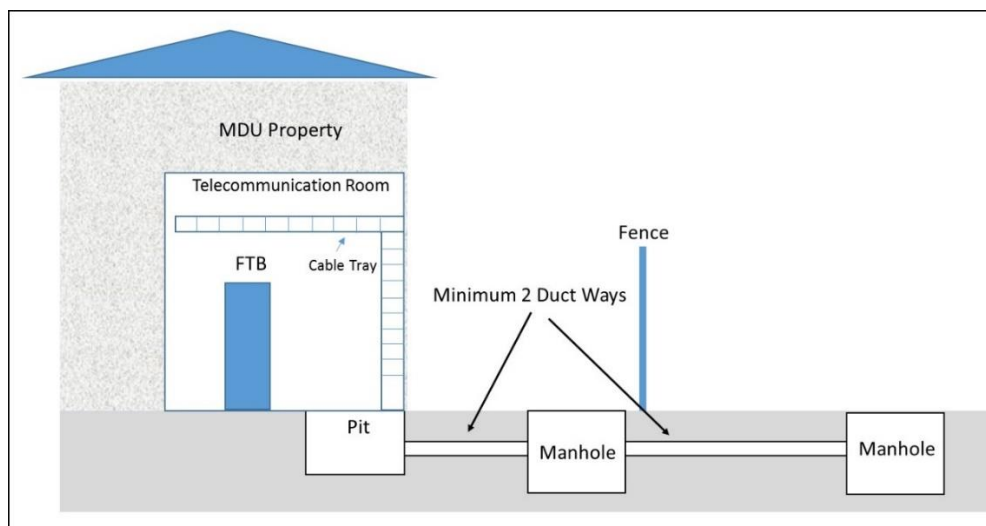

Figure 16. Manhole connection to the building

MCMC MTSFB TC G024:2020

5.4.1.3.3 Connection to housing estate and campus type premises

The manholes between common access manhole and premises access manhole shall be at least JC9C with 2 duct ways as illustrated in Figure 17. Property developer should consult NFP on the appropriate size of manhole for large development.

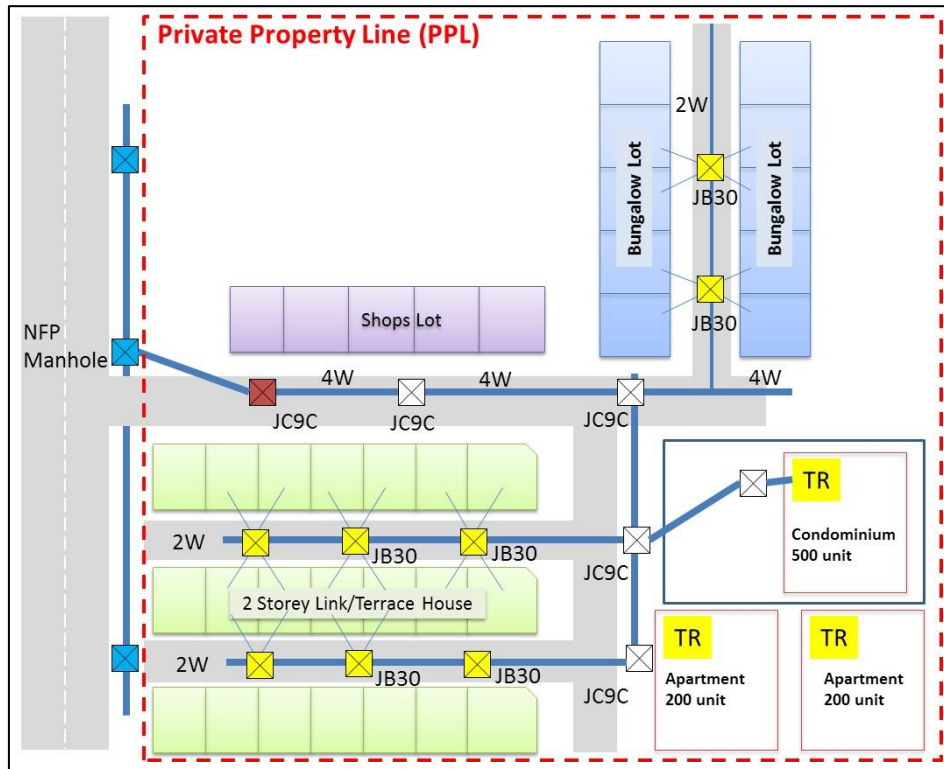

Figure 17. Connection for housing estate and campus type premises

5.4.2 Overhead infrastructure

5.4.2.1 Connection with NFP infrastructure

Development area designed with pole infrastructure and connect to NFPs pole shall be constructed as shown as Figure 18 below. The distance of the first pole that will connect with NFP pole shall be placed as closed as possible with maximum of 50 m from NFP pole. Any requirement for additional poles outside PPL, property developer may discuss with NFP through commercial arrangement for the best option. A proper handover agreement shall be carried out between property developer and NFP upon completion of the construction.

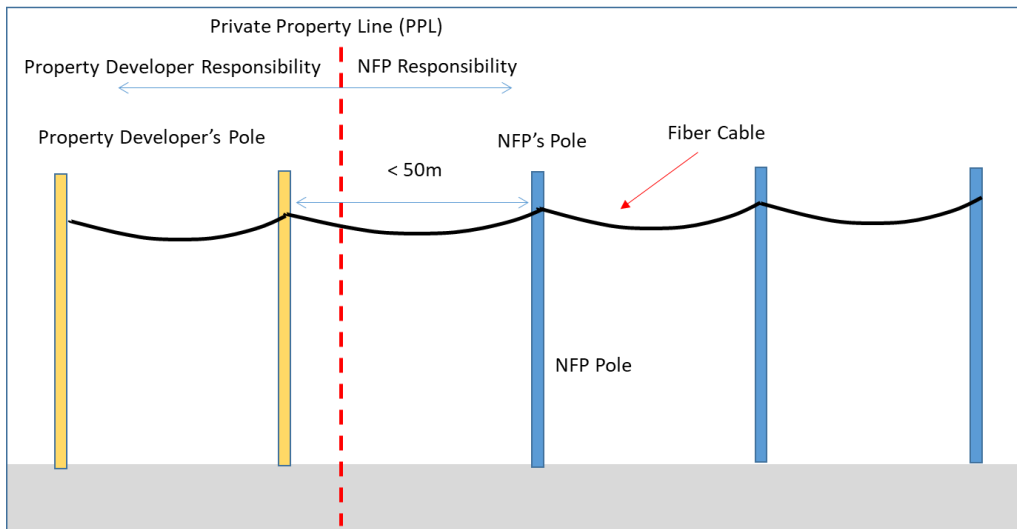

Figure 18. Overhead connection with NFP's Pole

Development area designed with pole infrastructure and connect to NFPs underground infrastructure shall be constructed as shown in Figure 19 below. A common access manhole adjacent to the first property developer's pole shall be provided by property developer.

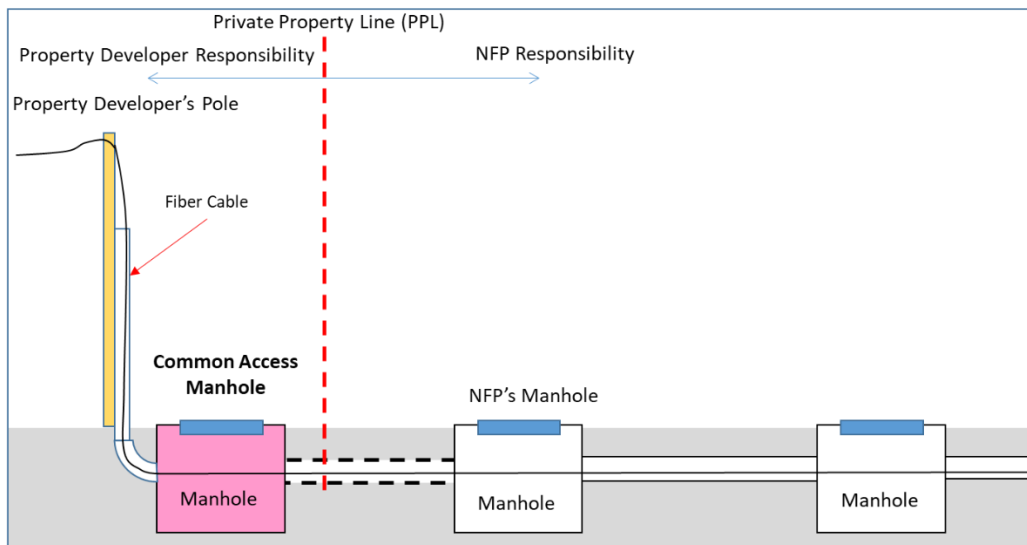

Figure 19. Overhead connection for pole type deployment

5.4.2.2 Pole distribution design

Only landed residential SDU is recommended to be served via pole.

Industrial or commercial properties is highly recommended to be served with underground infrastructure as the premises access connection.

Development area designed with pole infrastructure for connection via NFP's pole shall be prepared as shown in Figure 20 below.

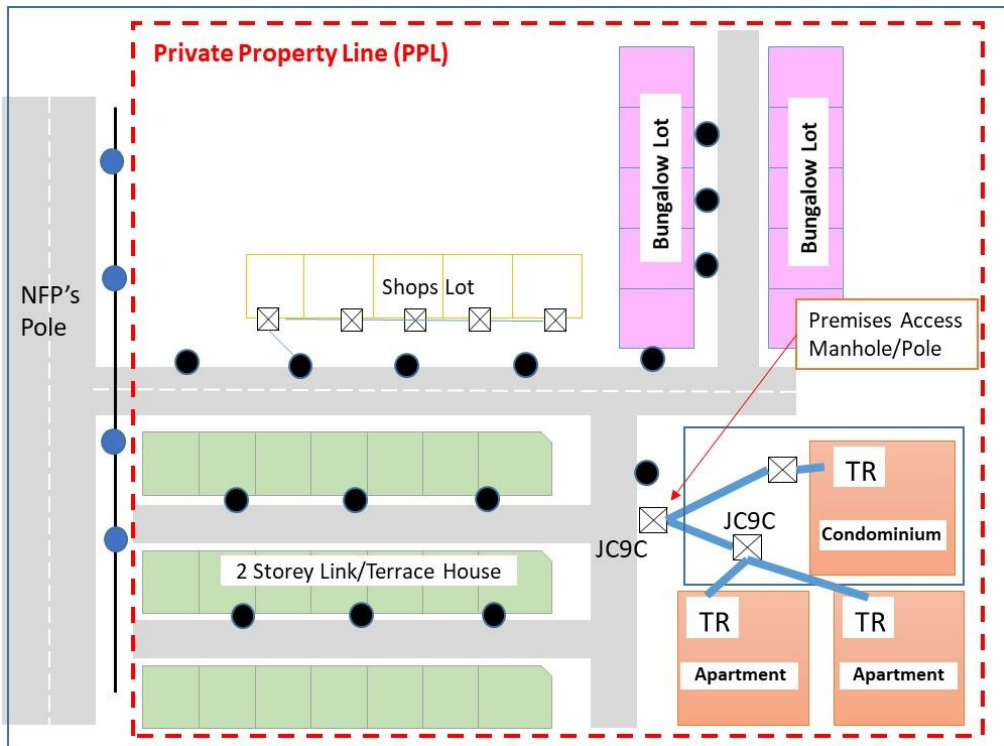

Figure 20 Pole distribution for connection via NFP's pole

Development area designed with pole infrastructure for connection via NFPs underground infrastructure shall be prepared as shown in Figure 21 below.

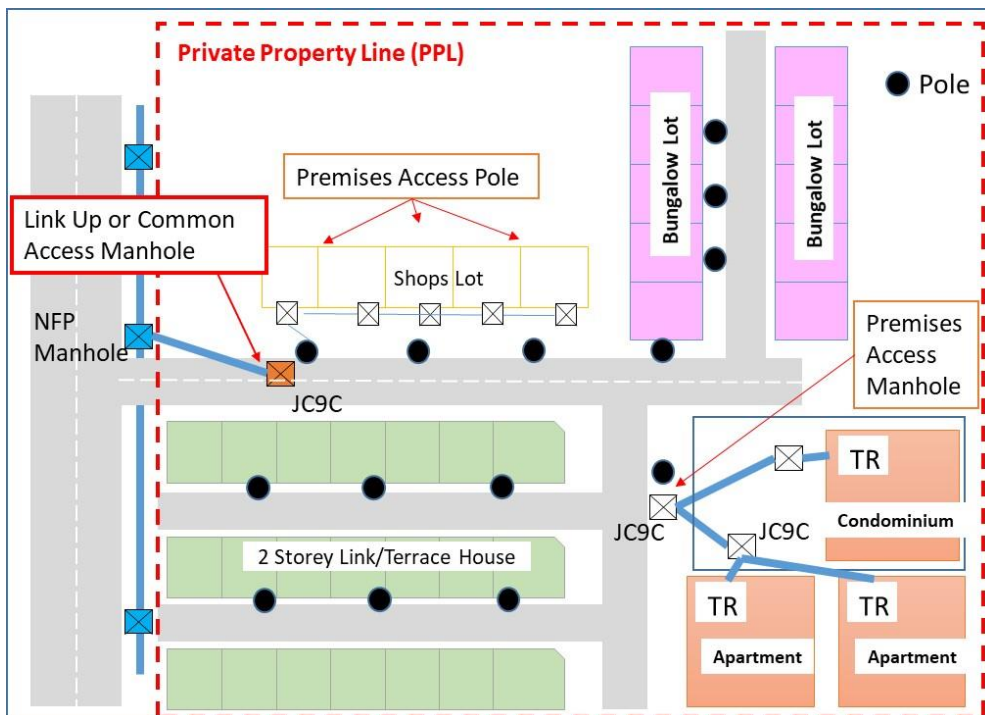

Figure 21 Pole distribution for connection via NFP's underground infrastructure

5.4.3 Premises access pole

Premises access pole refers to the pole that is used to connect with the customer premises. Every pole shall be located to serve 8 premises with maximum distance of 50 m as shown in Figure 22 below. The distance shall be measured between pole and premises FTB.

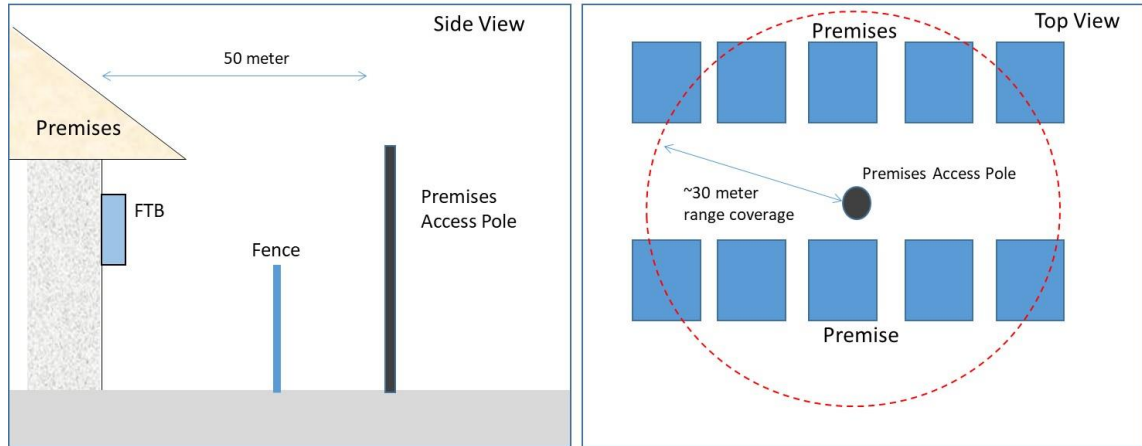

Figure 22. Premises access pole

5.4.4 Pole specification

All poles shall meet the specifications as specified in Telcordia GR-3159.

The poles should be generally installed by NFP. However, property developer may provide the poles based on the commercial arrangement with NFP. The pole specification and installation procedure shall follow as recommended by the selected NFP.

The length of the pole depends on the application. The minimum length of pole shall be as specified in Table 3.

Table 3. Pole length and application

Pole length (m)	Application
6.7	<ul style="list-style-type: none"> • Premises access pole • Premises back lane
7.5	<ul style="list-style-type: none"> • Low traffic road
9.0	<ul style="list-style-type: none"> • Road crossing

Concrete type of pole shall be used in development area. Every pole shall have a minimum of 8 points which shall be able to support with a minimum of 8 fibre cables. The load specifications shall be as specified in Table 4.

Table 4. Pole load specification

Specification	Minimum value
Maximum load/point	200 kg
Maximum total load	1,600 kg
Permanent bending load	30 %

MCMC MTSFB TC G024:2020

Minimum bending load	224 kg
----------------------	--------

5.4.5 Pole installation

Distance between poles shall be as shown in Table 5.

Table 5. Distance between poles

Location	Distance between poles (m)
<ul style="list-style-type: none"> • Premises access pole • Premises back lane 	20 - 30
<ul style="list-style-type: none"> • Along the road • Road crossing area 	30 - 50

For the case of non-flat ground level, the maximum difference of height between 2 poles shall be kept less than 300 mm as illustrated in Figure 23 below. If the distance cannot be met, distance between poles shall be reduced.

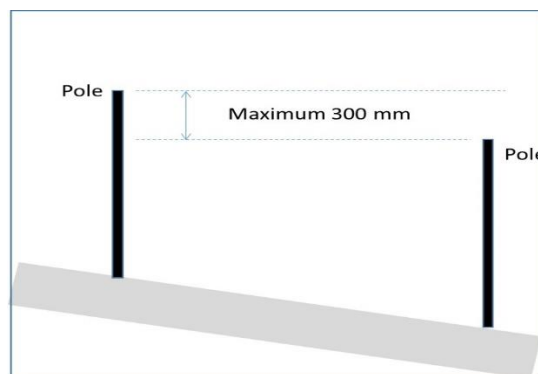

Figure 23. Non flat pole installation

Pole shall be installed at the minimum of 1,500 mm depth from ground surface. The concrete kicking block shall be used to support the pole. The top edge of concrete kicking block shall be installed at 150 mm from the surface level as illustrated in Figure 24 below.

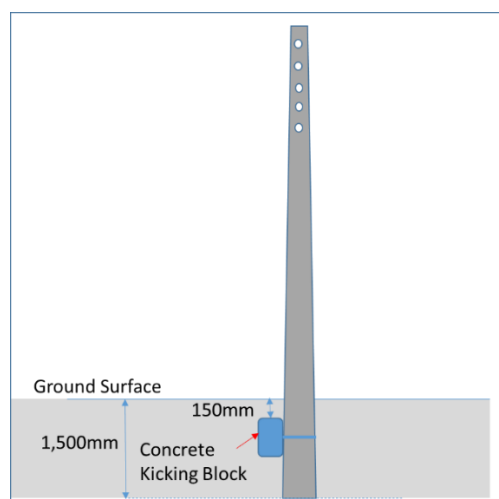

Figure 24. Pole depth installation

5.4.6 Accessibility

No charges shall be imposed by property developer or BM on NFP to access any in-building and external infrastructure including the installation of any equipment for fixed network facilities. Only authorised personnel by NFP shall be allowed to access in-building and external infrastructure.

5.5 In-building infrastructure requirement

5.5.1 Telecommunication Room (TR)

In general, the property developer shall provide TR for all MDU type of buildings. The property developer shall consult NFP in case TR is not to be provided. TR is required for the NFP to locate communications equipment and related elements to deliver the communication services to the building.

5.5.2 Space requirement

The adequate floor space area is required to cater immediate and also future demand. A minimum clear floor space of 750 mm is essential in front of all accessible points of the equipment in order to provide adequate working space for installation, testing and maintenance service. The TR shall be placed on the ground-floor area and connected to the manhole and duct-ways as required.

The room shall be located free of perceptible vibration. Ducting, sewage pipes, air conditioned pipes etc. shall not pass through the TR. The floor of the TR shall be of a material that is easy to clean and not susceptible to the accumulation of dust, flooring requirement is anti-static vinyl type mat and bonded to the earth bus bar. The room shall be flood-free. A 150 mm kerb across the doorway is required to prevent water from entering the room. The TR floor space dimension for each type of building shall be as specified in Table 6.

Table 6. TR floor space

Building type	Floor space (L x B x H) (m)	# Floor/wall opening (W x D) (m)	Door opening (W x D) (m)
Condominium and apartment			
x < 6 floors	4 x 4 x 3	0.4 x 0.15	2.5 x 1
6 < x < 16 floors	5 x 4 x 3	0.6 x 0.15	2.5 x 1
x > 16 floors	7 x 4 x 3	0.9 x 0.2	2.5 x 1
Low-cost flats			
x < 6 floors	3 x 4 x 3	N/A	2.5 x 1
6 < x < 16 floors	4 x 4 x 3	0.6 x 0.15	2.5 x 1
x > 16 floors	5 x 4 x 3	0.9 x 0.2	2.5 x 1
Office building			
x < 6,000 m ²	4 x 3 x 3	0.7 x 0.15	2.5 x 1
6,000 m ² < x < 20,000 m ²	4 x 4 x 3	1.0 x 0.2	2.5 x 1
20,000 m ² < x < 60,000 m ²	5 x 5 x 3	1.1 x 0.2	2.5 x 1
x > 60,000 m ²	7 x 6 x 3	1.1 x 0.2	2.5 x 1

Table 6. TR floor space (continued)

Building type	Floor space (L x B x H) (m)	# Floor/wall opening (W x D) (m)	Door opening (W x D) (m)
Shop house			
x < 6 storey	The requirement to be determined case by case	The requirement to be determined case by case	The requirement to be determined case by case
Others			
Industrial Lot	The requirement to be determined case by case	The requirement to be determined case by case	The requirement to be determined case by case
Hotel			
School			
Hospital			
Club house			

5.5.2.1 Electrical requirement

The TR shall be provided with electrical Alternating Current (AC) supply from the utility supplies at a nominal of 415 V, 3 phase, 4 wires, 50 Hz system or at a nominal voltage of 240 V AC single-phase system with solid earth system. The type of AC supply and rating will be dependent on the expected load.

The TR shall be equipped with a 20 A Three Phase and Neutral (TPN) metal clad Distribution Box (DB) of 20 A. The DB should be equipped with the following:

- a) Earth Leakage Circuit Breaker (ELCB);
- b) Automatic Restoration System (ARS) is an auto re-closure device that works with the ELCB;
- c) to normalise the power system for ensuring minimum system downtime and site attendance;
- d) surge protection system of 40 kA; and
- e) 20-way Main Circuit Breaker (MCB) for buildings with 6 floors and above.

The electrical supply should be connected to the essential power generator if provided. An earth leakage circuit breaker shall be installed inside the room. The TR shall be equipped with daylight type fluorescent lighting that can provide a minimum of 300 Lux luminance at floor level.

5.5.2.2 Earthing

The earthing system shall have a resistance to earth not greater than 10 Ω or as stipulated in BS 6651 and IEC 60364-1, and shall be terminated on an earth bus bar inside the room. The main earth conductor shall have a cross-section of not less than 70 mm² via the shortest routing. The earthing system shall be connected to the building main grounding. The grounding system termination is shown in Figure 25.

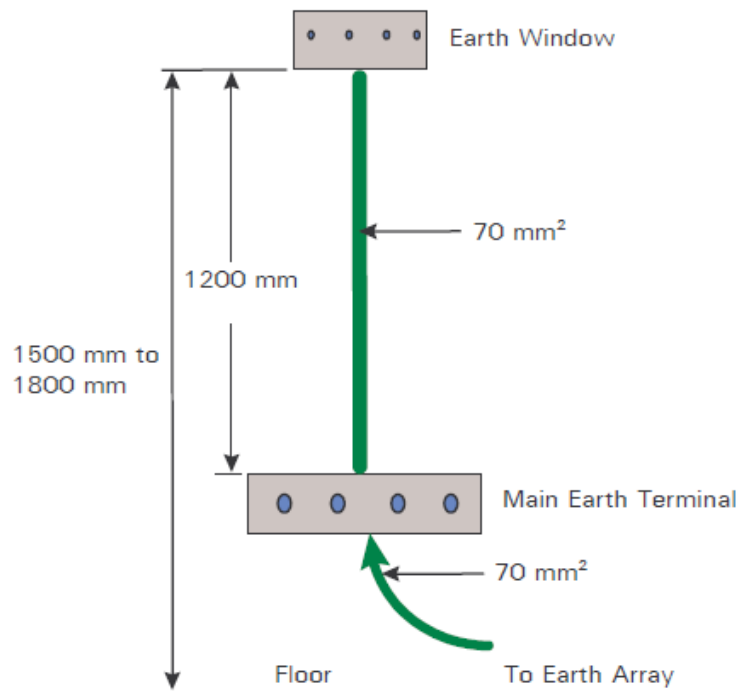

Figure 25. Grounding system termination

5.5.2.3 Temperature and ventilation

The TR shall be air-conditioned or equipped to maintain humidity and room temperature at 30 % to 50 % relative humidity and below 30 °C respectively under all conditions at all times.

The room shall be fitted with a ventilation fan system capable of 30 air change/min, activated when the room temperature rises above 35 °C. It is highly recommended the room to be equipped with air-condition all the time.

AC Power Distribution Board (ACPDB) in TR shall be equipped with Earth Leakage Relay (ELR) to fix the sensitivity setting reading.

5.5.2.4 Security

There should be no opening in the TR except for the door, the ventilation and cabling ducts. The door dimension shall be 1 m x 2.5 m. All windows shall be shut and sealed along the frames to keep out water and dust, and blind shall be provided to avoid direct sunlight. Solid walls shall be provided for heavy equipment mounting. The walls and ceiling shall be of normal finishing or painted with light-coloured vinyl emulsion or gloss paint.

The TR shall be locked at all times and only NFP authorised personnel shall be allowed to access. The key for this room shall be kept by the owner or the BM and made available to authorised personnel when required.

No water tank, main water drainage pipes shall be installed directly above the room. Property developer shall observe all relevant ordinance and regulation regarding the fire safety requirements during the design of the TR, by having:

- a) portable hand-operated fire extinguisher; and
- b) emergency lighting connection to a backup power supply.

MCMC MTSFB TC G024:2020

Smoke detection device shall be installed inside the TR and shall be connected to the central control of the BM office. The room shall be fitted with a fire door as per 'Jabatan Bomba dan Penyelamat Malaysia' approval.

5.5.2.5 Floor loading

The TR shall be designed for a minimum distributed load of 500 kg/m² and concentrated floor loading of 910 kg/m².

5.5.2.6 Room height

The clear ceiling height of TR shall not be less than 3 m, to enable installation of equipment, cabinets and cabling.

5.5.2.7 Room arrangement

The recommended TR arrangement is shown in Figure 26. The FTB that connecting all the cabling to individual premises must be located at the rightmost position as this is the nearest point leading to the internal riser as illustrated in Figure 26.

The NFP's network elements may be located adjacent to the FTB. The FTB shall be connected to the building internal cabling and become a connection point with the NFP's network element. The size of the FTB depends on the number of premises inside the building.

NFP's network elements shall be located in the same row or adjacent to the FTB less than 20 m distance.

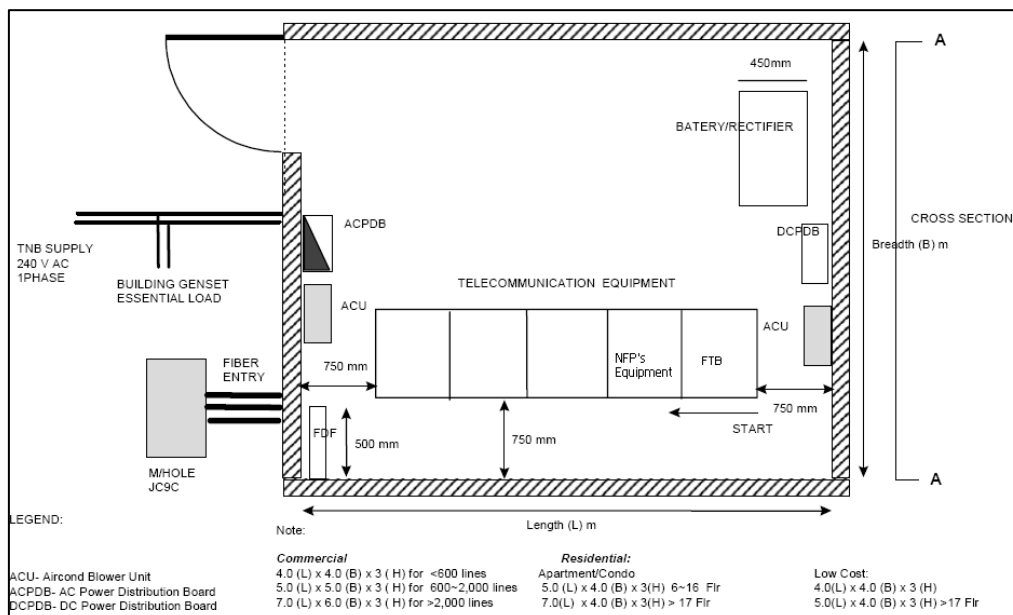

Figure 26. TR arrangement

5.5.2.8 Fibre Optic Trunking System (FOTS)

A proper Fibre Optic Trunking System (FOTS) shall be prepared inside the room to provide the proper cable route. Property developer shall consult with NFP for the design and suitable route of the FOTS. All the cable and patch cord shall use the FOTS accordingly. The FOTS size depends on the building capacity. The recommended minimum FOTS size is 6 inch (150 mm) medium size of the building (less than 100 units). Sample of FOTS as shown in Figure 27.

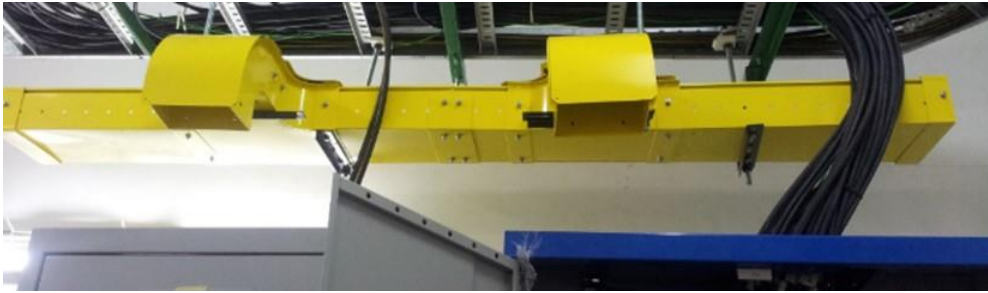

Figure 27. Sample of FOTS

5.5.3 Riser

To obtain maximum benefit from the distribution system, the riser duct shall be placed centrally with respect to the distribution in which it is to serve. To facilitate the installation and maintenance of horizontal cables, the distance between the riser duct and the outlet point in the home unit shall be kept as short as possible. A 150 mm high kerb shall be provided across the doorway to prevent water from getting in.

For building without TR, the cable riser shall be sited in an easily accessible area inside the building like staircase landing area. The riser shall be fitted with sufficient fluorescent lighting to facilitate work and the word 'Telecommunications Services' shall be displayed on the door of the riser closure. A minimum of 2 units of 13 A power sockets shall be provided at the alternate building floor in the riser to cater for the need of fixed network services distribution equipment. However, if needs arise for larger blocks (i.e. more than 10 apartments units per floor), 2 units of 13 A switch socket-outlets for every floor is recommended.

The riser shall only be used for fixed network services. The following services are not allowed to share this riser:

- a) water piping;
- b) firefighting;
- c) building electrical system;
- d) gas distribution; or
- e) any other services that may cause moist, danger or any harmful effect on human life.

Access to each riser is necessary on each floor and shall always be available from a corridor or other common area to avoid undue disturbance to occupants. The riser shall have a hinged and locked door on every floor, and shall be fireproof. The riser door key shall be kept by the building owner for safe custody.

The size of the riser shall be based on the type of building as in

Table 7.

Table 7. Riser size

Building type	Riser		
	Cable trunking	Floor opening (W x D)	Closet space (W x D)
Condominium and apartment			
x < 6 floors	100 mm x 75 mm x 3	0.4 m x 0.15 m	0.9 m x 0.6 m
6 < x < 16 floors	150 mm x 100 mm x 3	0.6 m x 0.15 m	1.2 m x 0.6 m
x > 16 floors	150 mm 100 mm x 3	0.9 m x 0.2 m	1.5 m x 0.8 m
Low-cost flats			
x < 6 floors	100 mm x 75 mm x 3	N/A	N/A
6 < x < 16 floors	150 mm x 100 mm x 3	0.6 m x 0.15 m	1.2 m x 0.6 m
x > 16 floors	150 mm x 100 mm x 3	0.9 m x 0.2 m	1.5 m x 0.8 m
Office building			
x < 6,000 m ²	150 mm x 100 mm x 3	0.7 m x 0.15 m	1.2 m x 0.9 m
6,000 m ² < x < 20,000 m ²	150 mm x 100 mm x 3	1.0 m x 0.2 m	1.5 m x 0.9 m
20,000 m ² < x < 60,000 m ²	150 mm x 100 mm x 3	1.1 m x 0.2 m	1.8 m x 1.2 m
x > 60,000 m ²	150 mm x 100 mm x 3	1.1 m x 0.2 m	1.8 m x 1.2 m
Shop house			
x < 6 storey	100 mm x 75 mm x 3	N/A	N/A
Others			
Industrial lot	Requirement to be determined case by case.		
Hotel			
Schools			
Hospital			
Club house			

5.5.4 Vertical trunking

The trunking is required for laying the cable inside the building and acts as the protection and cable guide. The trunking located inside the riser is referred as vertical trunking. Open ladder, cable tray and closed trunking are the types of trunking that can be used as a vertical trunking.

The example of vertical trunking location for the MDU is shown in Figure 28.

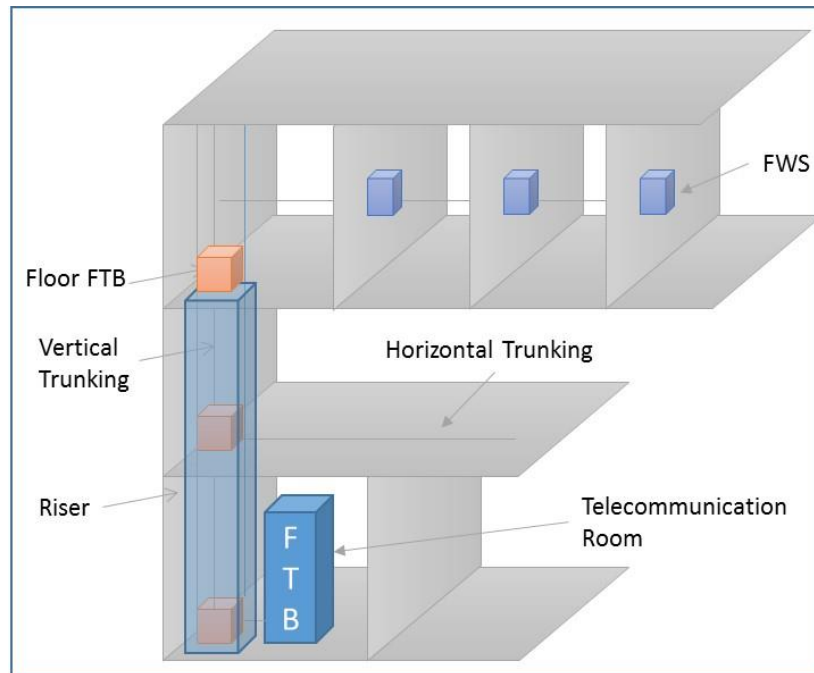

Figure 28. Trunking for MDU

The trunking bending radius shall be greater than 10 times of the trunking size to ensure that the fibre cable meet the minimum bending radius.

Vertical closed cable trunking and the riser can be shared between broadcast and other communication services. The arrangement of these cables in the riser shall be as follows:

- a) from the left is for radiocommunications (cellular network) services;
- b) the center is for communication (fixed network) services; and
- c) from right side is for broadcast services.

Closed trunking shall be used and solidly grounded to provide shielding between different services. The trunking shall be galvanized steel plate, epoxy powder coated against corrosion with a finishing of light blue paint.

5.5.5 Horizontal trunking or conduit

Horizontal trunking or conduit shall be provided to connect from riser on each floor to every Fibre Wall Socket (FWS).

The horizontal trunking or conduit shall be made from PVC or harder type. All conduits or cable enclosure shall be completely concealed and shall not protrude to reduce the aesthetics either within or outside of the premises.

The fixed network horizontal trunking shall be separated and dedicated to related services and type of cabling such as follows:

- a) fibre optic cable for broadband and voice services;
- b) fibre optic or metal-based cable for Local Area Network (LAN);

MCMC MTSFB TC G024:2020

c) extra Light Voltage (ELV) services such as CCTV, alarm system, etc.

Sharing of services apart from those listed above is strictly prohibited.

The size of the horizontal trunking shall be 100 mm x 25 mm for on wall or floor and 100 mm x 50 mm for on ceiling along the corridor shall be according to the number of cables as shown in Table 108.

Table 8. Horizontal trunking

Number of cables	Number of trunkings on wall /floor (100 mm x 25 mm)	Number of trunkings on ceiling (100 mm x 50 mm)
Less than 10	1 unit	1 unit
10 to 20	2 units	2 units
More than 20	N/A	Comply with 50 % space factor

The trunking bending radius shall be greater than 10 times of the trunking size to ensure that the fibre cable meets the minimum bending radius.

5.5.6 Fibre Termination Box (FTB)

FTB shall be provided as the connection point between in-building and external fibre. It shall be located as follows:

- MDU with TR - inside the TR (as shown in Figure 29);
- High-rise SDU - riser or staircase area (as shown in Figure 30); and
- Landed SDU - outside the premises wall (as shown in Figure 31).

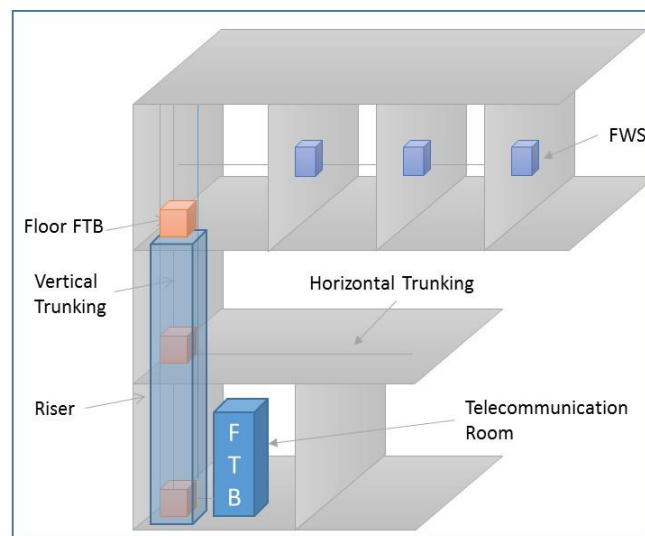

Figure 29. FTB locations for MDU

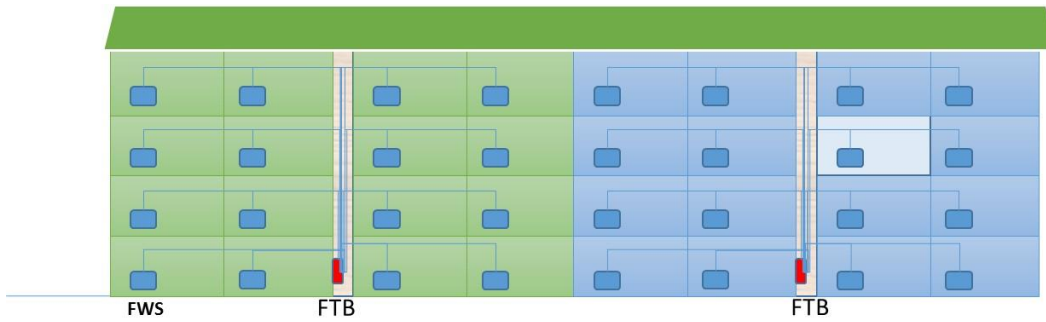

Figure 30. FTB locations for high-rise SDU

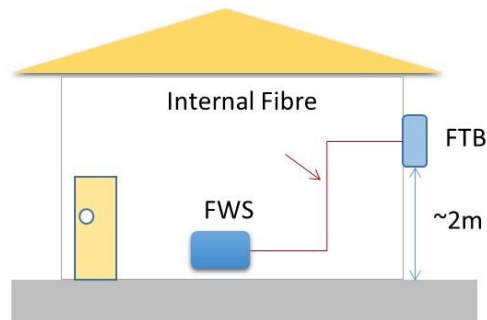

Figure 31. FTB locations for landed SDU

FTB for SDU shall be located at 2 m height from the ground level outside of the wall. Intermediate FTB may also be placed at riser for MDU as distribution point of high capacity to smaller capacity fibre. FTB shall always be locked and secured to protect from any damage or contamination. Samples of FTB for MDU and SDU are shown in Figure 32 and Figure 33 respectively.



Figure 32. FTB for MDU

MCMC MTSFB TC G024:2020

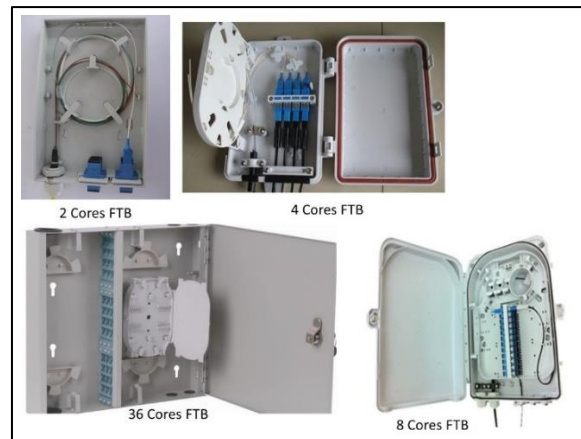

Figure 33. FTB for SDU

The minimum of 2 sets of SC/UPC or SC/APC connectors shall be provided inside the FTB for every premises unit. Both connectors shall be connected with internal fibre to FWS.

Detailed specifications of FTB are specified in Annex A.

5.5.7 Fibre Wall Socket (FWS)

FWS shall be provided as a termination point for the internal fibre cable and act as a connection point to BTU or Optical Network Unit (ONU). The locations of FWS shall be as shown in Figure 34.

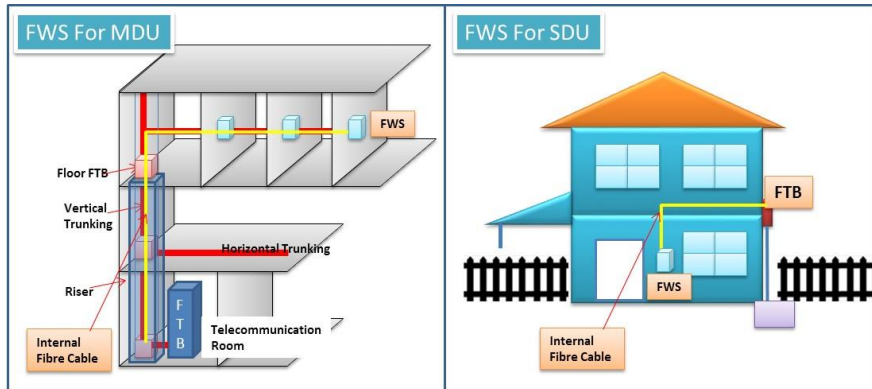

Figure 34. FWS locations for MDU and SDU

A minimum of one unit of FWS shall be provided inside each premises.

FWS shall meet the requirements as follows:

- The minimum of 2 sets of SC/UPC or SC/APC connectors shall be provided inside the FWS. Both adaptors shall be connected with internal fibre to FTB.
- Equipped with shutter and dust cap to protect the connector;
- Made from non-corrosive material or treated metallic material to resist corrosion;
- Located 300 mm above the floor level and 300 mm from the corner of the wall;
- Located adjacent to electrical points; and

f) FWS shall support a minimum of 2 fibre cores.

Sample of FWS is shown in Figure 35.

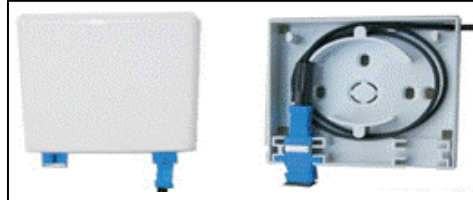

Figure 35. Sample of FWS

5.5.8 Customer Premises Equipment (CPE) outlet

CPE outlet is used to connect the internal cabling system with the dedicated service equipment. The type of outlet is depending on CPE type. The minimum type of CPE outlet shall be provided as below:

- a) Registered Jacket type 45 (RJ45) outlet socket for internet-based CPE which connected via Category 5 Enhance (CAT5e) or higher cable; and
- b) Registered Jacket type 11 (RJ11) outlet socket for analogue telephone which connected via Category 3 (CAT3) or higher cable.

CPE outlet is recommended to be located at the living room’s adjacent power socket and FWS to facilitate upcoming interactive services which will require feedback channel over the BTU.

Wall outlet boxes and plates shall be fabricated from non-corrosive material or from metallic material treated to resist corrosion.

6. Cabling requirements

Detailed requirements on the fibre type and specifications are as specified in Annex B and C.

6.1 Cable distribution requirement

The design for cable distribution in SDU, MDU and campus type is illustrated in Figure 36.

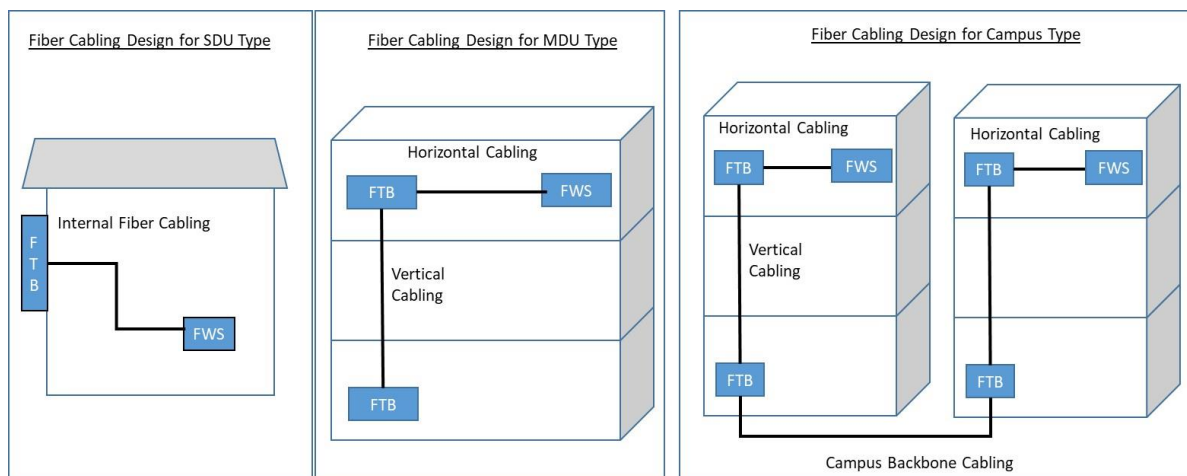

Figure 36. Cable distribution for SDU, MDU and Campus Type

MCMC MTSFB TC G024:2020

The fibre cable shall be laid as follows:

- a) fibre cable from the NFP will be laid via their manholes and duct-ways and finally to the customers building via the customer manhole and duct-ways;
- b) fibre cable will be terminated onto the FTB; and
- c) cables from the FTB will be connected to the FWS of the individual premises' units such as via the vertical and horizontal distribution.

The cabling requirement for every premises shall be as follows:

- a) Number of fibre core required:
 - i) minimum of 2 cores for residential type;
 - ii) minimum of 4 cores for business type, however property developer should consult the NFP for the appropriate number of cores based on the actual requirement.
- b) The connector type shall be SC/UPC or SC/APC which depends on NFP and type of services, therefore property developer shall consult with NFP for the appropriate type.
- c) The cable type shall be single mode fibre and comply with ITU-T G.657.A specifications.

6.2 Cabling for Single-Dwelling Unit (SDU)

6.2.1 Cabling for SDU served via pole

FTB at the customer premises will be the cabling demarcation boundary between NFP and property developer as shown in Figure 37.

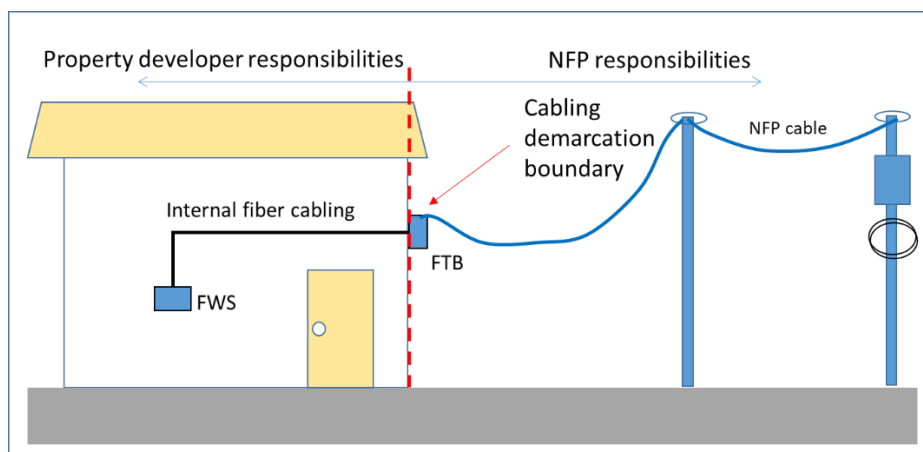

Figure 37. Cabling demarcation boundary for pole type

NFP shall be responsible for cabling between NFP's pole to FTB which will be installed during service activation.

Property developer shall be responsible for internal cabling from FTB to FWS inside of every premises unit.

6.2.2 Cabling for SDU served via underground

The pedestal manhole will be the cabling demarcation boundary between NFP and property developer as shown in Figure 37.

Property developer shall be responsible for the cabling from FWS to the pedestal manhole.

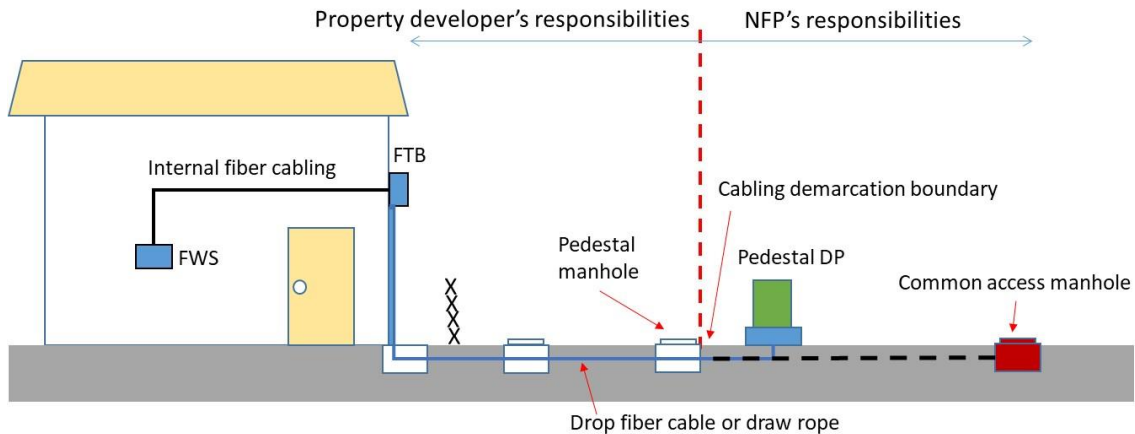

Figure 38. Cabling demarcation boundary for underground type

6.2.3 Drop fibre cable for SDU served via underground

For SDU served via underground, drop fibre cable shall be prepared between FTB and pedestal manhole, where:

- a) on FTB side, it shall be terminated inside the FTB with connector.
- b) on the pedestal manhole side, it shall be coiled inside the pedestal manhole without any connector.

Pedestal DP should be installed by NFP during activation by pulling and terminating the drop fibre to the pedestal DP. The drop fibre shall fulfil the following requirements.

- a) properly stored inside the pedestal manhole;
- b) coiled inside the plinth or pedestal manhole with around 10 m length (property developer may consult with NFP for the accurate length);
- c) labelled with each unit of premises number for easy identification and the label shall be made from polyethylene or any material which is able to sustain up to 10 years or more to avoid faded or damaged tag;
- d) not exceeding 50 m length to ensure power attenuation loss is within allowable budget and easy to be maintained; and
- e) minimum of 2 cores for each unit of premises.

6.2.3.1 Draw rope

As an option, for property whereby the distance between FTB and the pedestal manhole is less than 20 m, draw rope is allowed to replace the drop cable. Property developer shall ensure the draw rope is in smooth condition and able to be used to pull drop fibre later.

MCMC MTSFB TC G024:2020

Each draw rope shall be tagged and labelled with premises number, properly and securely stored inside the pedestal manhole.

All conduits or cable jointing closures shall be completely concealed to avoid any water leakage and shall not protrude to maintain the aesthetics either within or outside the customer premises. The sample connection for drop fibre is shown in Figure 39.

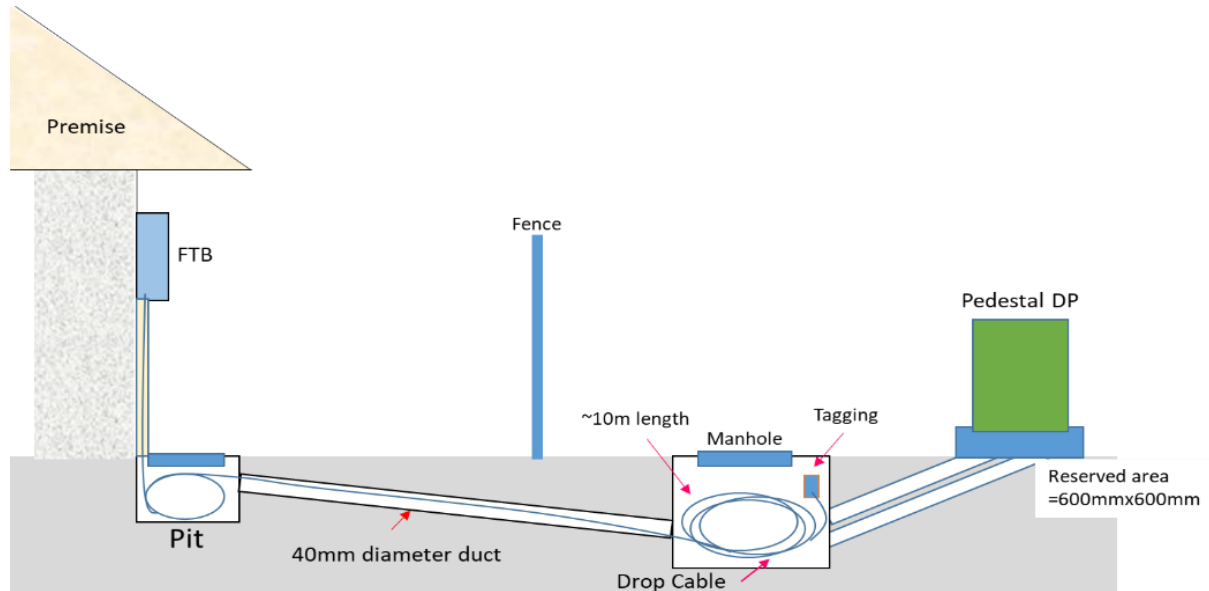

Figure 39. Connection of underground drop fibre

6.2.4 Cabling for standalone premises type

The premises owner shall be responsible for cabling as below:

- from FWS to FTB for connection to NFP via pole; and
- from FWS to NFP's manhole for connection to NFP via underground.

The cabling for standalone premises served via pole and underground is as shown in Figure 40.

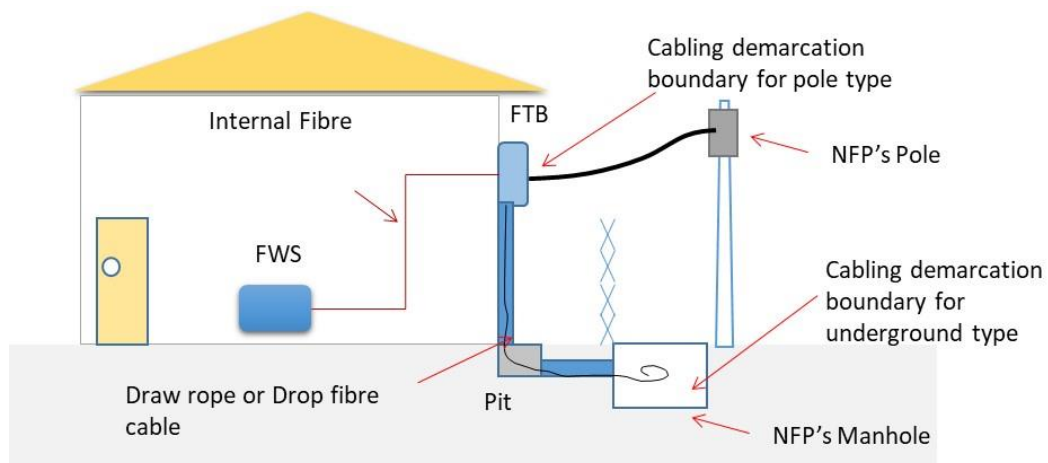

Figure 40. Cabling for standalone building

In case of connection to NFP via underground, premises owner shall be responsible to prepare FWS, internal fibre, FTB, pit and duct to NFP's manhole with the following specifications:

- a) premises owner is allowed to prepare either a draw rope or drop fibre between FTB and NFP manhole;
- b) draw rope or drop fibre cable shall be properly tagged and labelled with premises unit number.

Cabling requirements for standalone premises type shall follow as explained in 6.2.1 and 6.2.2.

6.2.5 Cabling for town house type

Town house refers to the premises or properties that have multiple units inside the building with a single access.

The cabling design and demarcation points for town house served via pole and underground are as shown in Figure 41 below.

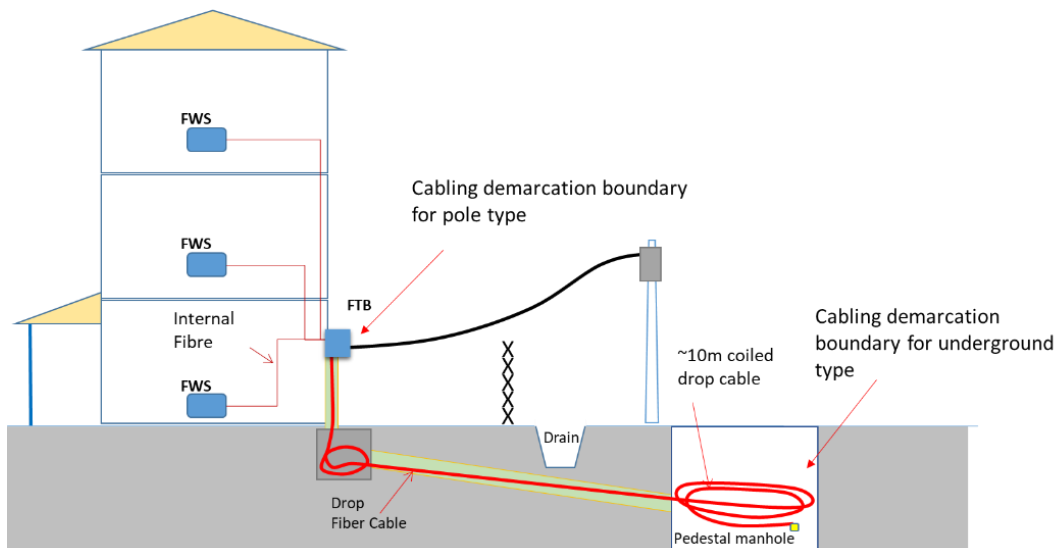

Figure 41. Cabling for town house type

Cabling requirements for town house shall be as specified in 6.2.1 and 6.2.2.

FTB shall be installed at a common area and be accessible at all time.

6.2.6 Cabling for high-rise SDU

High rise SDU is the premises less than 6 floors and generally not equipped with TR. The example of high-rise SDU are shop lots, apartment and business building. The cabling for high-rise SDU without TR is shown in Figure 42.

MCMC MTSFB TC G024:2020

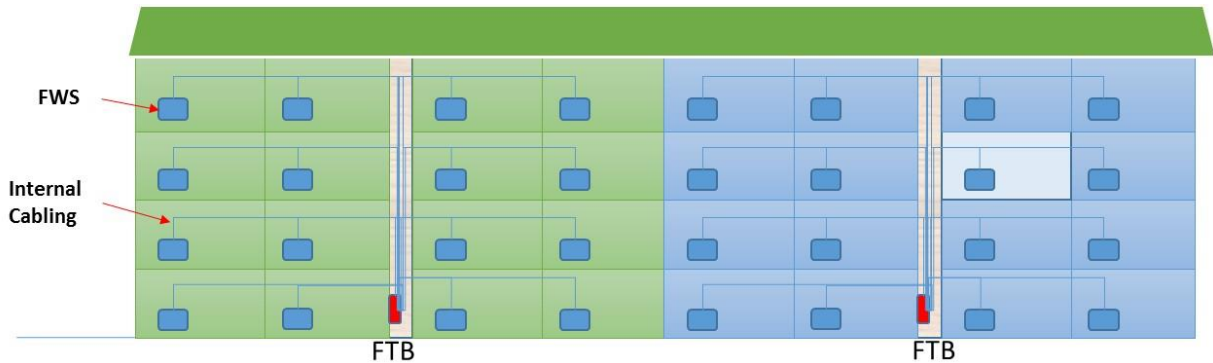

Figure 42. Cabling for high-rise SDU without TR

Property developer shall prepare the FWS inside each premises unit and connected to FTB via internal fibre. FTB shall be placed in a common area and have easy access at all the time. FTB will act as connection point between NFP and each individual premises unit. A reserved space of minimum 600 mm x 600 mm beside the FTB shall be provided as shown in Figure 43.

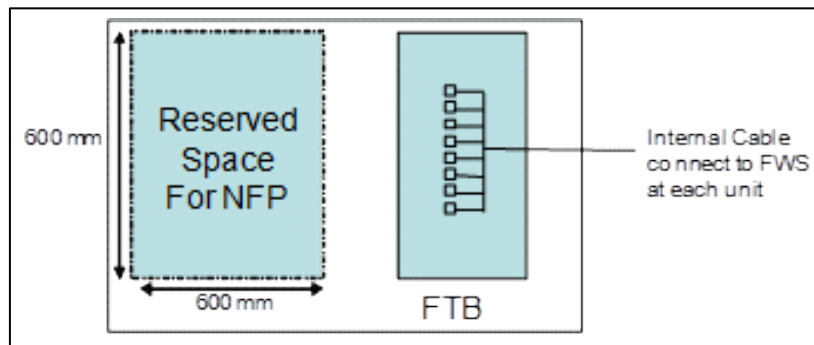

Figure 43. Reserved space near FTB

The reserved space shall be used by NFP to locate related network elements. NFP will connect the prepared cabling with the network element inside the FTB during the service activation.

Internal fibre between FTB and FWS shall be installed inside the trunking or fully concealed. The layout of the internal fibre into the customer premises depends on the customer's preference. Each internal fibre core terminated inside the FTB shall be tagged and labelled with the premises number.

6.2.7 Power link budget for SDU cabling

Power link budget refers to the total attenuation loss allowable in certain portion of the network. Power link budget for SDU is measured as below:

- between FWS and FTB for SDU served via pole, and
- between FWS and pedestal manhole for SDU served via underground.

Property developer shall perform the attenuation loss measurement of cabling for each premises and provide the test results to NFP during the acceptance process.

Total attenuation loss shall not exceed the following requirements:

- a) 1.6 dB for SDU served via pole; and
- b) 2.3 dB for SDU served via underground.

6.2.7.1 Power link budget estimation for SDU served via pole

Sample calculation of allowable power link budget for SDU served via pole is shown in Table 9.

Table 9. Sample of cabling attenuation loss calculation for SDU served via pole

No.	Location	Item	Unit loss (dB)	Unit	Total loss (dB)	Details
1	FTB	FA-SC connection point	0.7	2	0.7	1 unit of FA-SC connector = 0.3 dB ~ 0.5 dB
2	Internal fibre	Cable 1,310 nm = 0.4 dB/km	0.4	50 m	0.02	Horizontal cable (50 m) = 0.02 dB
3	FWS	FA-SC connection point	0.7	1	0.7	1 unit of FA-SC connector = 0.3 dB ~ 0.5 dB
4	Other	Other marginal loss	0.18	1	0.18	N/A
Total					1.6	Total = 1.6 dB
NOTE: For further details of internal fibre, please refer ITU-T G.652.D or G.657.A						

In the sample, connector type at FTB and FWS uses the Field Assembly Standard Connector (FA-SC) which generally has higher attenuation loss. As an alternative, the use of Splice on Connector (SOC), fusion splicing or other method that may provide lower attenuation is highly recommended.

The length of fibre also contributes to the attenuation loss and shall be managed properly to ensure the total power link budget does not exceed the requirements.

6.2.7.2 Power link budget estimation for SDU served via underground

Sample calculation of allowable power link budget for SDU serve via underground is shown in Table 10. The measurement is between the drop fibre’s end inside the pedestal manhole and FWS inside the premises.

Number of connectors, joints or length of cable are not specified and may be designed according to property developer’s preference.

In the sample below, the connector type at FTB and FWS is FA-SC which generally has higher attenuation loss. As an alternative, the use of SOC, fusion splicing or other method that may provide lower attenuation is highly recommended.

MCMC MTSFB TC G024:2020

Table 10. Sample of cabling attenuation loss calculation for SDU served via underground

No.	Location	Item	Unit loss (dB)	Unit	Total loss (dB)	Detail
1	Drop fibre end (inside pedestal manhole)	FA-SC connection point	0.7	1	0.7	1 unit of FA-SC connector = 0.3 dB ~ 0.5 dB
2	Drop fibre	Cable 1310 nm = 0.4 dB/km	0.0004	50 m	0.02	Drop fibre (50 m) = 0.02 dB
3	FTB	FA-SC connection point	0.7	1	0.7	1 unit of FA-SC connector = 0.3 dB ~ 0.5 dB
4	Internal fibre	Cable 1310 nm = 0.4 dB/km	0.0004	50 m	0.02	Internal fibre (50 m) = 0.02 dB
5	FWS	FA-SC connection point	0.7	1	0.7	1 unit of FA-SC connector = 0.3 dB ~ 0.5 dB
6	Other	Other marginal loss	0.16	1	0.16	Other = 0.16 dB
Total					2.3	Total = 2.3 dB

NOTE: For further details of internal fibre, please refer ITU-T G.652.D or G.657.A

6.3 Cabling for Multi-Dwelling Unit (MDU)

Internal cabling for MDU covers the elements from the FTB inside TR to the FWS inside the individual premises.

Cabling for MDU consist of 3 main elements as below:

- a) vertical cabling;
- b) horizontal cabling; and
- c) campus backbone cabling

6.3.1 Cabling demarcation

Cabling demarcation for MDU is as shown in Figure 44.

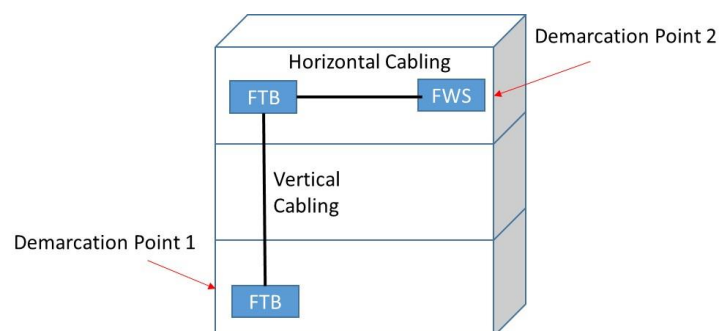

Figure 44. Network boundary for MDU

The responsible entities for MDU are NFP, property developer, BM and individual premises owner. The cabling demarcations are as follows:

a) Demarcation point 1 (FTB):

The cabling from Demarcation Point 1 to outside of the building shall be provided by NFP and the cabling to inside of the building until FWS shall be provided by property developer and be owned and maintained by the premises owner or BM; and

b) Demarcation point 2 (FWS):

The cabling from Demarcation Point 2 to the CPE is between premises owner and NFP. NFP will install the cable and CPE during service activation. The ownership of both elements depends on the service agreement between NFP and premises owner.

NFP shall install their equipment inside the TR. The connection between NFP's network and property developer's FTB will only be performed upon service subscription where NFP will do the provisioning process at customer premises.

6.3.2 Vertical cabling

Vertical cabling refers to the cabling between FTB inside the TR and FTB on each floor within the same building. Vertical cabling shall be provided by the property developer. After completion of the building construction, the ownership of the vertical cabling will be transferred to the BM. BM shall maintain and ensure all the cablings are in good and working condition.

Minimum number of fibre cores for vertical cabling shall follow the rules as below:

a) For residential building

Minimum number of fibre cores : 2 x total premises unit + 30 % extra

b) For commercial building

Minimum number of fibre cores : 4 x total premises unit + 30 % extra

Example calculation of minimum number of vertical fibre cores capacity for residential building are as follows:

Number of units in the building	: 100 units
Minimum number of vertical fibre cores	: (2 cores x 100 units) + (30 % x 100 units) = 200 + 30 = 230 cores

6.3.3 Floor FTB

Floor FTB is a connection point between vertical cabling and horizontal cabling on every floor. Floor FTB is highly recommended to be prepared for easier expansion and maintenance of the vertical cabling.

The connection between vertical cabling and horizontal cabling inside the floor FTB can be done through direct splice joint or using the SC/UPC or SC/APC connector and pre-connected upon completion of the development.

MCMC MTSFB TC G024:2020

Vertical cabling can also be directly terminated at FWS inside the individual premises without using the floor FTB.

6.3.4 Horizontal cabling

Horizontal cabling refers to the floor distribution cabling between floor FTB to every premises FWS with the capacity as below:

- a) A minimum of 2 cores for each premises for residential type; and
- b) A minimum of 4 cores for each premises for business type. However, 10% extra cores are recommended to be prepared. Properly developer is recommended to consult with NFP for the appropriate capacity planning.

The cabling for horizontal fibre cabling should be secured through the following:

- a) exposed wall or surface ducting or trunking;
- b) concealed ducting inside the wall;
- c) concealed ducting under the floor; or
- d) conduit ducting through the ceiling.

The size of the trunking and ducting depends on the capacity and size of the cable. The trunking or ducting of horizontal cabling shall be made from PVC or higher material. The minimum diameter of the trunking is as follows:

- a) PVC conduit size of 50 mm diameter;
- b) PVC casing size of 100 mm x 25 mm; and
- c) metal clad trunking size of 100 mm x 25 mm.

6.3.5 Campus backbone cabling

Campus backbone cabling refers to the cabling from the NFP's interface TR to the link-up property's TR. All campus backbone cabling shall be directly terminated or pre-connected at NFP interface TR with clear and proper tagging and labelling. No additional patching is allowed to connect the link-up building during the service activation process. High capacity fibre cable (48 cores and above) is recommended to be used for campus backbone cabling.

Campus backbone cabling shall be prepared by property developer and shall be terminated at both property's FTB inside the TR. Number of cores required shall be similar as specified in 6.3.2 for vertical cabling. Sample of campus backbone cabling is shown in Figure 45.

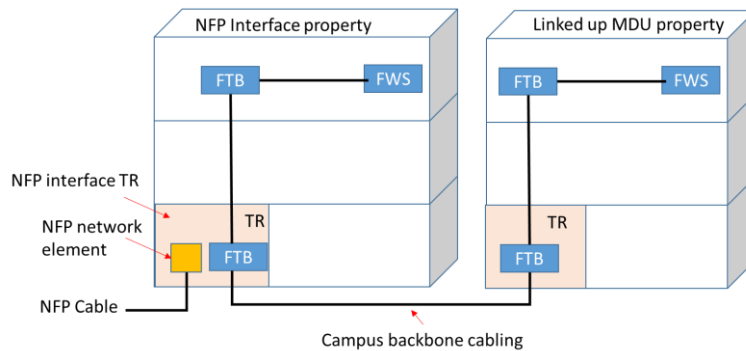

Figure 45. Campus backbone cabling

Total insertion loss between NFP interface TR's FTB and FWS inside the premises at link-up property shall not exceed 2.3 dB. If the insertion loss exceeds the requirement, the link-up property shall be designed to allow NFP to install the equipment inside the link-up property's TR. NFP should be allowed to use the campus backbone cabling for this purpose if applicable.

6.3.6 MDU internal cable distribution design

Cabling distribution design inside the development area depends on property type, capacity, type of material, competency of the contractor, and property developer preferences. Property developer is recommended to discuss with the NFP for the best design and method to be adopted. Sample designs that may be adopted by property developer are specified below.

6.3.6.1 Design 1: High capacity vertical cable

Design 1 is highly recommended for high capacity type of building. The example of design is as shown in Figure 46.

The methods for Design 1 are as follows:

- a) Several high capacity cables (96 cores and below) erected from TR main FTB through each floor and tapping out several cores at each level. It requires high skilled installation technique to tap out the related fibre cores at each floor.
- b) At every floor, vertical cable is terminated depending on the number of cores required at that floor.
- c) The erected vertical cable cores shall be jointed with horizontal cable through direct splicing or using a connector inside the floor FTB.
- d) It is recommended to use drop cable or indoor cable type for horizontal cabling which generally consists of single or multiple cores.
- e) Each horizontal cable shall be terminated at individual FWS.
- f) Each unit shall use a different horizontal cable.

MCMC MTSFB TC G024:2020

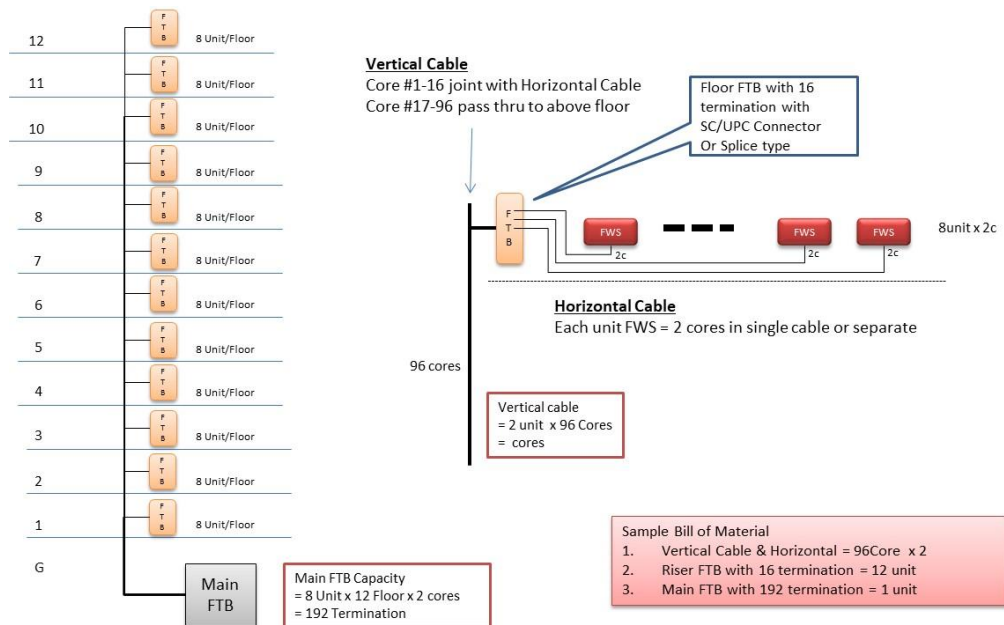

Figure 46. Cabling Design 1 - High capacity vertical cable

6.3.6.2 Design 2: Medium capacity vertical cable

Design 2 is highly recommended for high or medium capacity building. The methods for Design 2 are as follows:

- Several medium (24 - 96 cores) capacity cables erected from TR's main FTB to every 3 floors.
- The vertical cable cores shall be jointed with every floor's horizontal cable through direct splicing or using a connector inside the floor FTB. A single floor FTB is not allowed to be shared with more than 3 floors and shall be placed in the centre floor. Every floor FTB is only allowed to serve one floor above or one floor below the horizontal cabling.
- The erected vertical cable cores shall be jointed with horizontal cable through direct splicing or using a connector inside the floor FTB.
- It is recommended to use drop cable or indoor cable type for horizontal cable which generally consists of single or multiple cores. Each horizontal cable shall be terminated at individual FWS.
- Each unit shall use different horizontal cable.

The example of design is as shown in Figure 47 below.

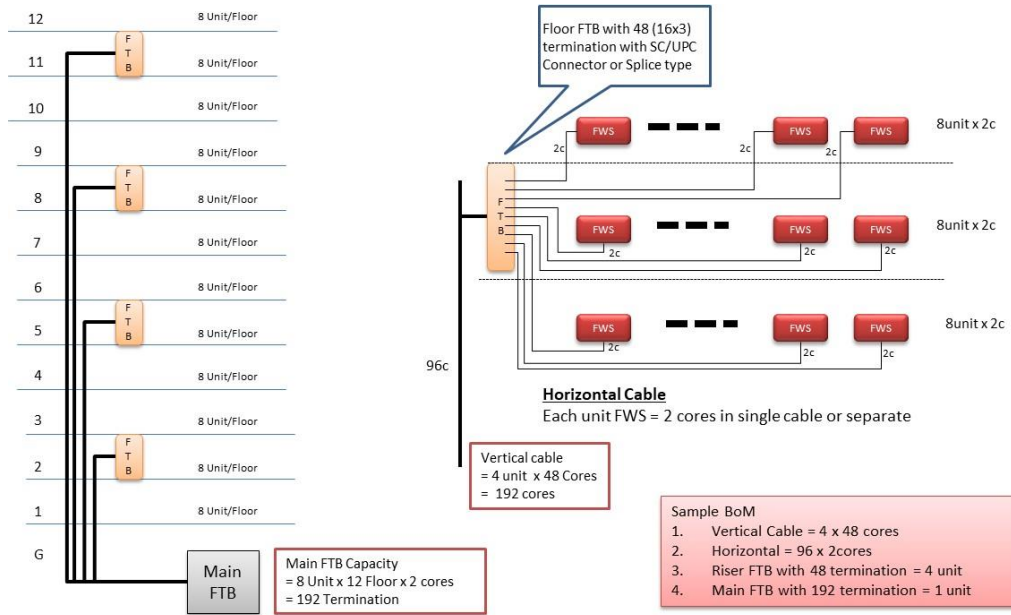

Figure 47. Cabling Design 2 - Medium capacity vertical cable (high capacity)

6.3.6.3 Design 3: Single vertical cable to every floor

Design 3 is highly recommended for low and medium capacity building. The methods for Design 3 are as follows:

- a) Single medium capacity of vertical cable (12 - 48 cores) erected from TR main FTB to every floor and jointed with horizontal cable at each floor.
- b) At every floor, one vertical cable is erected depending on the number of cores required at that floor.
- c) The erected vertical cable cores shall be jointed with horizontal cable through direct splicing or using a connector inside the floor FTB.
- d) It is recommended to use drop cable or indoor cable type for horizontal cable which generally consists of single or multiple cores.

Each horizontal cable shall be terminated at individual FWS. Each unit shall use different horizontal cable. The example of design is as shown in Figure 48.

MCMC MTSFB TC G024:2020

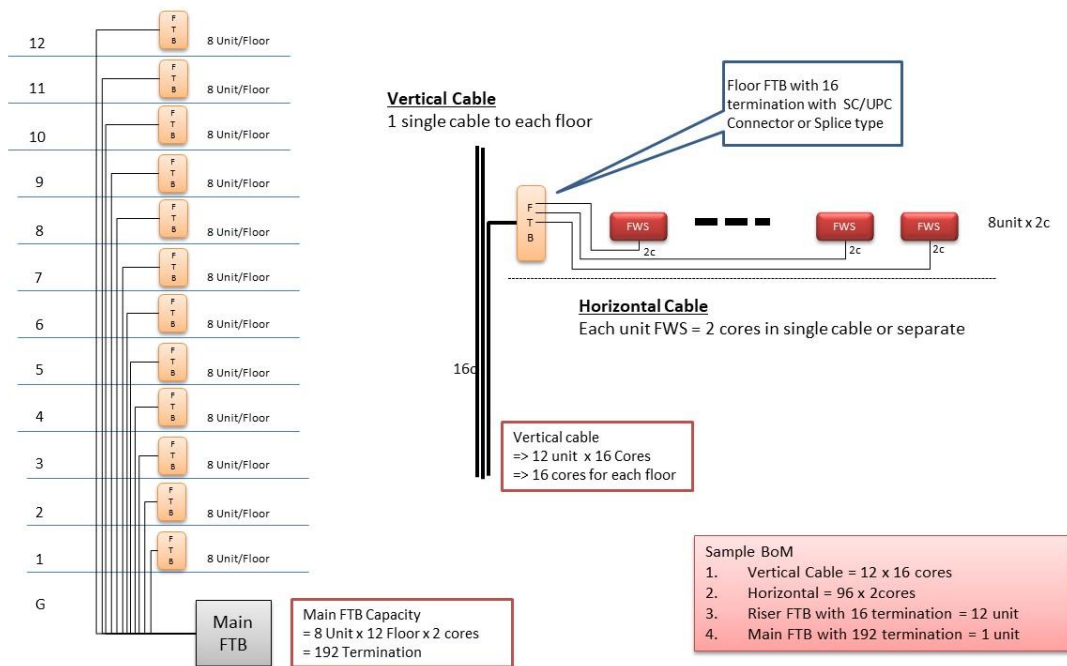

Figure 48. Cabling Design 3 - Single vertical cable to each floor

6.3.6.4 Design 4: Single cable direct to each premises unit

Design 4 is highly recommended for low capacity building. A single 2 cores of indoor drop cable is erected from TR's FTB directly to each individual premises FWS. The example of design is as shown in Figure 49. The methods for Design 4 are as follows:

- Each unit shall use different cable.
- No floor FTB is required. However, for better cable maintenance and management in future, it is also recommended to have the floor FTB.
- Blown fibre system is an optional method with minimum 3.5 mm micro duct inner diameter size that can be considered. Detailed specifications of micro duct are specified in Annex D.

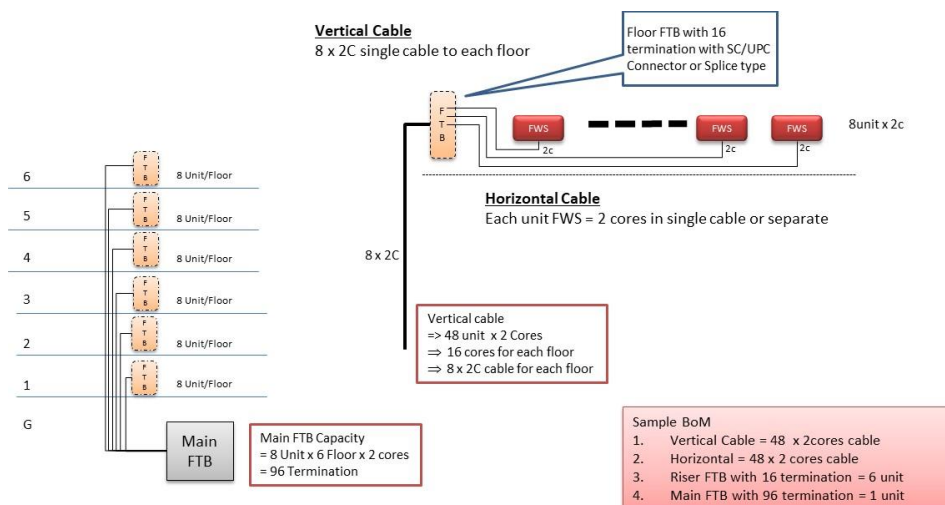

Figure 49. Cabling Design 4 - Single cable directly to premise unit

6.4 Cabling for campus

For campus type, generally all the properties are connected to a single NFP interface FTB through campus backbone cabling. The sample is as shown in Figure 50 below.

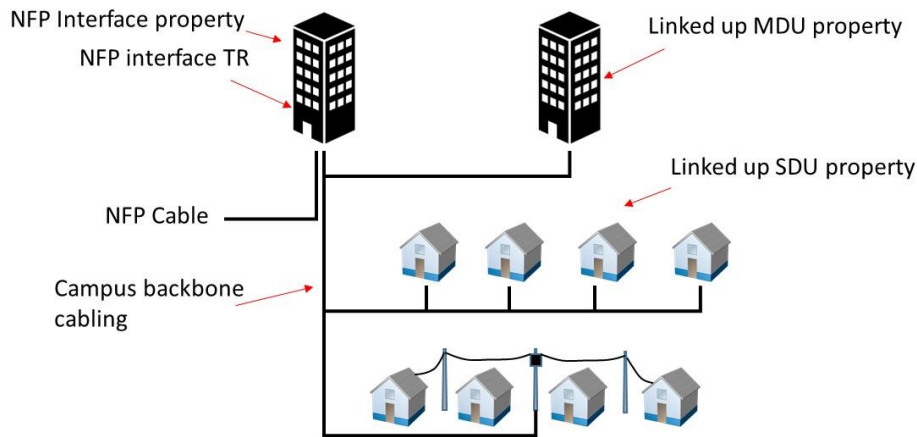

Figure 50. Sample of cabling for mixed property development area

Campus backbone cabling shall be prepared by property developer to link up all the buildings with the NFP interface property. The cabling shall be prepared and pre-connected from NFP interface property FTB inside the TR to every individual unit FWS. The total loss between FTB and FWS shall be maximum 2.3 dB.

6.5 CPE cabling design

CPE cabling refers to the cabling between BTU and CPEs to provide other value added services. CPE cabling may be considered for better customer experience to enjoy the broadband and value added services provided by NFP. With a proper design of CPE socket and cabling, the end user may have the flexibility to provision their services at various locations depending on their preference.

The recommended CPE cabling type and design are as follows:

- a) Category 3 (CAT3) or higher cabling with RJ11 socket type for normal analogue voice services. However, if VOIP is used, the cabling type shall be Category 5 (CAT5) with RJ45 socket.
- b) CAT5e or higher cabling with RJ45 socket for broadband services. The cabling is from BTU to CPE which may inclusive of Wi-Fi access point, internet switch, computer, IPTV STB, or any device terminal that requires internet connection.
- c) Single mode or multi-mode fibre for higher broadband speed or other type of CPE that may support fibre interface.

CPE cabling design connecting FWS and BTU to CPE sockets according to the type of services are shown in Figure 46.

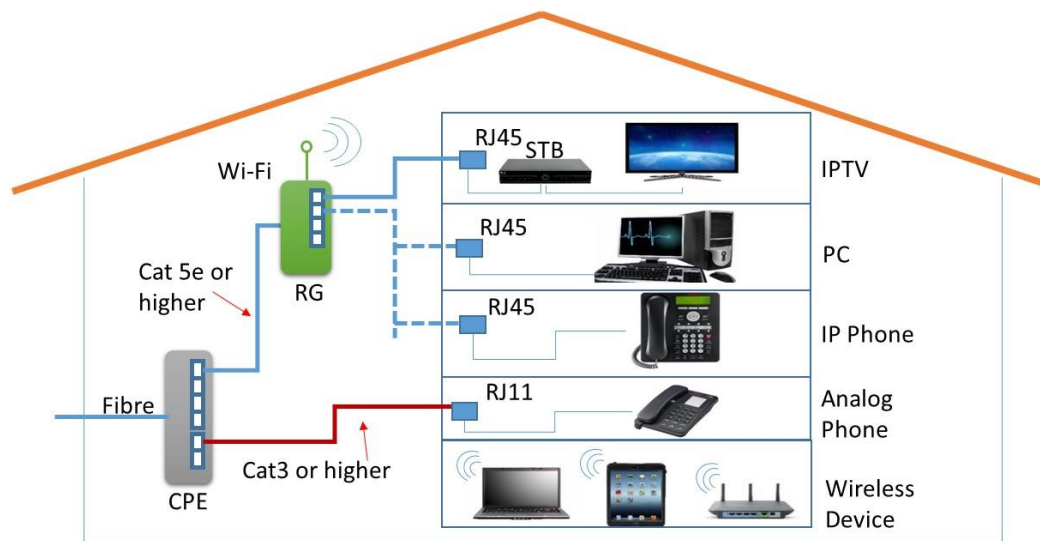

Figure 46. CPE cabling design

6.6 Cable specification

Cable specification for premises internal fibre shall be as shown in Table 11.

Table 11. Specification of premises internal fibre

Cable	Cabling portion	Specification
Campus backbone	Main building's FTB TR to other building's FTB	Single mode ITU-T G.652.D
Vertical cable	FTB at TR to each floor FTB	Single mode ITU-T G.652.D or ITU-T G.657.A
Horizontal cable and premises internal cable	FTB or floor FTB to individual unit premises FWS	Single mode ITU-T G.657.A
Drop cable	Individual unit premises and underground type premises	Single mode ITU-T G.657.A

All fibre cables shall be made from Low Smoke Zero Halogen (LZSH). For business area, anti-rodent material is recommended to prevent the fibre breakdown in future.

6.6.1 Internal fibre cable

Internal fibre cable is used for corridor and indoor cabling. It is suitable to be used for:

- MDU horizontal cabling
- premises internal cable
- drop cable for underground type of deployment

The structure of internal fibre is shown in Figure 47. The fibre shall be single mode type and comply with ITU-T G.657. Detailed specifications are provided in Annex B.

Internal fibre cable is suitable for aerial, underground duct, inside the under-floor trunking, over ceiling trunking or exposed fixing along the wall. The characteristics are as follows:

- a) small outer diameter, light weight, suitable for branching, indoor, limited room;
- b) reserved tearing gap of optical cable can separate the fibre easily without instruments, which is convenient to construct; and
- c) adopting small winding radius fibre with 15 mm and even 10 mm, suitable for indoor routing under the instance of sudden turning, for instance wall-pole corner and indoor smooth panel.

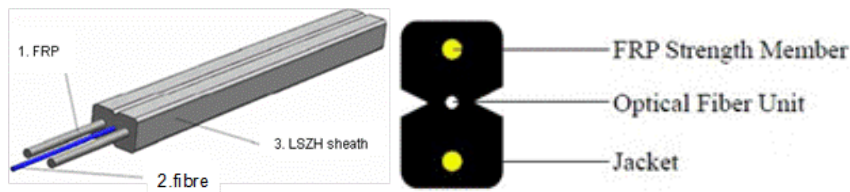

Figure 47. Structure of internal fibre cable

In addition, there are 3 specifications for this type of cable (1, 2 or 8 cores), configured according to different requirements.

The main advantages of the indoor flexible fibre cables are:

- a) easy split construction where the jacket can be peeled to open without using any tool;
- b) fibre is stripped and cleaved using conventional tools;
- c) readily available compatible interconnection components from multiple international vendors;
- d) complies to ITU-T and IEC standards; and
- e) multi-fibre core version of the same cable can be used as distribution cable (aerial or underground).

All cables shall be made from Low Smoke Zero Halogen (LZSH) and anti-rodent material and shall be installed through the open or closed riser trunking. Fibre Reinforced Plastic (FRP) or Aramid / Kevlar reinforced type is recommended.

6.6.2 Vertical and campus backbone cable

Cable specification for campus backbone cable and vertical cable is usually the same. However, for campus backbone, it is usually erected through underground. Therefore, the underground type of cable shall be used.

The types of cable that can be used for vertical cabling are:

- a) normal conventional FOC or generally known as round cable;
- b) indoor tight buffer cable;
- c) loose tube cable; or
- d) blown fibre (detailed specifications are provided in Annex C).

All cables shall be single mode type and comply with the specifications of ITU-T G.652.D or G.657.A. Sample of campus backbone and vertical cable is shown in Figure 48 and Figure 49.

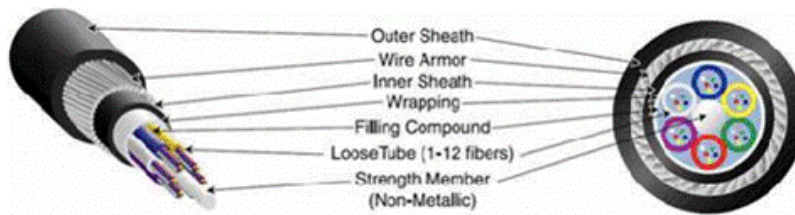

Figure 48. Possible vertical fibre cable design - Loose tube



Figure 49. Possible vertical fibre cable design - Ribbon

Underground cables are designed for high pulling tension and lubricants are used to reduce friction on longer pulls. Automated pulling equipment that limits pulling tension shall be able to protect the cables.

For very long runs or those with more bends in the conduit may require intermediate pulls through the manhole or any suitable pit.

Blown fibre technique may be used as an alternative to install the vertical and campus backbone cabling. It requires a special low friction vacuum duct and shall be used together with microcable type. Blown cable solution is as shown in Figure 50 below.



Figure 50. Possible microcable with microduct

Connection of underground cables using fusion splice method are generally stored above ground in a pedestal or in a vault underground. Sufficient excess cable is needed to allow splicing in a controlled environment, usually a splicing tray, and the storage of excess cable shall be considered in the planning stage.

6.6.3 CPE cabling

The cable type for CPE outlet cabling depends on the CPE port interface, type of service and required bandwidth. The services are categorised by the various signal, frequency bandwidth, and data transmission speeds. The minimum specification of the cabling type to be prepared by property developer is Cat5e type for the broadband services and Cat3 for analogue telephone service. For other type of services, it shall be as shown in Table 12.

Table 12. CPE cable types and related supported services

Cable type	Bandwidth	Application limit	Remark
Cat 3 (ISO/IEC 11801 Class C TIA/EIA 568 B)	16 MHz	For voice telephony and ADSL in building or inter building	Minimum requirement
Cat 5e (ISO/IEC 11801 Class D TIA/ EIA 568 C)	> 100 MHz	For data transmission up to 1 GB/s transmission rate	For distance up to 100 m
Cat 6a ISO/IEC 11801 Class D (TIA/ EIA 568 C)	250 MHz to 500 MHz	For data transmission up to 10 GB/s transmission rate	For distance up to 100 m
Cat 7 ISO/IEC 11801 Class D (TIA/ EIA 568 C)	600 MHz	For data transmission up to 10 GB/s transmission rate	For distance up to 100 m
Cat 8 ISO/IEC 11801 Class D (TIA/ EIA 568 C)	2,000 MHz	For data transmission up to 40 GB/s transmission rate	For distance up to 100 m
Fibre Optic (Multi-mode OM2/OM3/OM4)	> 200 MHz/km Depends on light source	For data transmission up to 10 GB/s transmission rate	For distance beyond 100 m
Fibre Optic (Single-mode)	Depends on light source	For data transmission > 10 GB/s transmission rate	For distance beyond 100 m

6.7 Labelling and tagging

6.7.1 Tag material and specification

Cable tag is used to identify the cable information such as core number, origin and destination of the cable. All fibre cables shall be tagged properly at every termination point and cable end. All tags shall be stated clearly and sealed with transparent material for easy to read. Sample of recommended tagging method is as shown in Figure 51.



Figure 51. Sample of recommended tagging system

Cable tag shall use clear and strong material such as plastic, nylon, vinyl or PE. The tag shall comply with UL 94 V Fire Retardant.

All information on tag shall be machine printed and can easily be read. The printed material shall sustain, not paled or faded for a minimum 10-year. Usage of paper or market pen is strictly not allowed.

MCMC MTSFB TC G024:2020

Suitable tag size shall be used according to cable, pigtail or fibre core size. The generic recommended size is 1 cm x 2 cm flag type as shown in Figure 52.

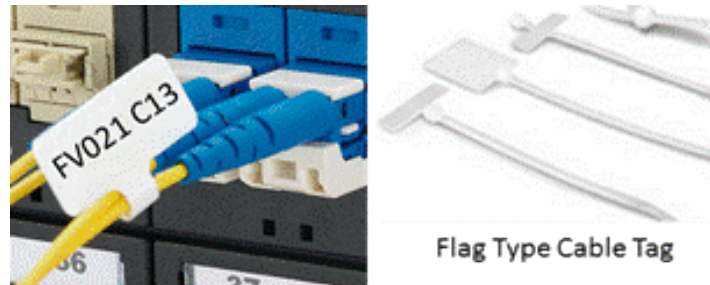

Figure 52. Cable tag

Tag colour shall be white background with black font. Sample of vertical cable tag is shown in Figure 53.

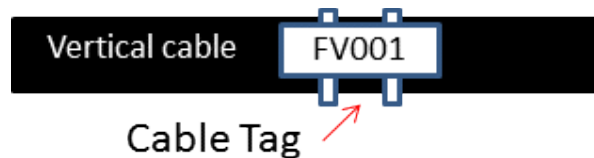

Figure 53. Vertical cable tag

6.7.2 Labelling and tagging for SDU cabling

All internal cabling fibre cores shall be tagged and labelled with core number or any relevant information. The sample is as shown in Figure 54.

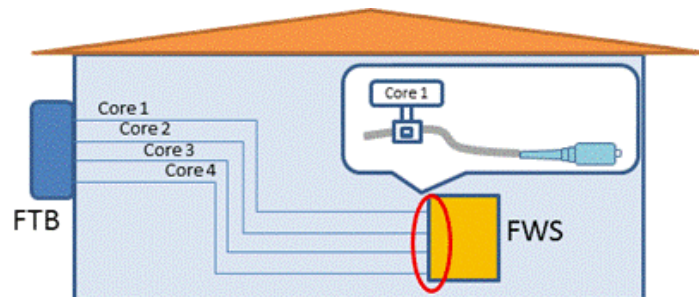

Figure 54. Labelling and tagging for premises internal cabling

However, if a single 2 cores of drop cable type is used inside individual premises, the labelling and tagging may not be required since it can be identified with the fibre core colour code - Blue and Yellow. Blue is for Core 1 and Yellow is for Core 2. Each fibre core needs to be correctly connected as both ends to avoid the reverse core symptom. The sample is as shown in Figure 55.



Figure 55. Colour code for 2 cores of drop cable

Tagging and labelling of drop cable are required at the pedestal manhole interfacing with the NFP network side for SDU served via underground infrastructure. The tagging information shall clearly state a premises unit number for easier identification. The sample is as shown in Figure 56.

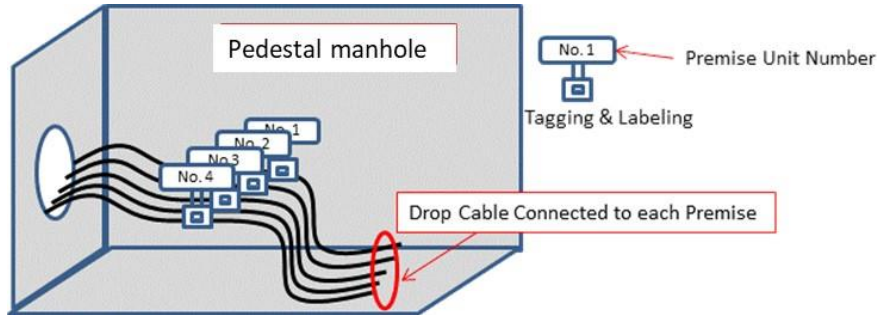

Figure 56. Labelling and tagging for SDU served via underground

6.7.3 Labelling and tagging of FWS and FTB

The identification shall be stated clearly at FWS and FTB port as shown in Figure 57.

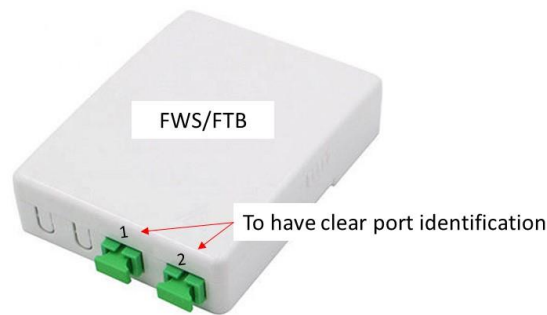

Figure 57. FTB and FWS port identification

6.7.4 Labelling and tagging for MDU's cabling

All cablings for MDU shall have a code or naming convention and shall be tagged properly for smooth service activation and restoration process. All cable information also need to be inventoried and a copy of inventory information shall be submitted to the NFP during cabling approval process.

All information of the cabling inventory shall be placed and indicated clearly inside TR or FTB for easier reference. BM shall record and update the information whenever there are any changes.

Code or naming convention for vertical and horizontal cabling shall follow as shown in Table below.

The table shall be placed inside the TR's FTB.

Table 13. Code for internal vertical and horizontal cable

Item	Vertical cable		Riser info	Horizontal cable	
	Cable number	Core number	Floor	Cable number	Core number
Code	FV xxx	xxx	FLxxx	FHxxx	xxx
Example	FV001 - FV999	000 - 999	FL020	FH001 – FH999	000 - 999

MCMC MTSFB TC G024:2020

Vertical cable with FHxxx code shall be tagged at:

- a) entrance of FTB inside TR;
- b) entrance to the duct or riser inside TR; and
- c) each floor riser.

Horizontal cable with FVxxx code shall be tagged at inside floor FTB (if any).

6.8 Testing and commissioning

All fibre cores shall be tested upon the completion of end-to-end cabling system. Minimum test parameter is total insertion loss of every fibre core. Other parameters such as optical return loss, component insertion loss, splice loss and distance may also be considered to ensure the cabling is at the best condition.

Total attenuation loss shall be measured using Optical Time Domain Reflectometer (OTDR), Optical Loss Test Set (OLTS) or Set of Light Source and Power Meter. All test equipment shall be configured with wavelength of 1310 nm.

Testing should comprise of a bi-directional end-to-end OTDR trace performed according to TIA/EIA 455-61 or ISO/IEC 11801 or a bi-directional end-to-end power meter test performed according to TIA/EIA 455-53A or ISO /IEC 11801. Each link that does not conform to the standard requirement shall be brought into compliance.

Total attenuation loss between FTB and FWS shall follow as show in Table 74 below: All measurements shall be performed using 1310 nm wavelength.

Table 74. Test location and maximum allowable loss

No.	Property type	Test point A	Test point B	Maximum loss
1.	SDU - pole type	Each individual premises FWS	FTB outside the premises	1.6 dB
2.	SDU - underground type	Each individual premises FWS	NFP interfacing manhole	2.3 dB
3.	MDU - single building	Each individual premises FWS	FTB inside TR	2.3 dB
4.	MDU - multi-building	Each individual premises FWS	FTB inside NFP interfacing TR	2.3 dB

6.8.1 Optical Loss Test Set (OLTS) test method

OLTS is a tool to measure point to point attenuation loss in a single cabling. OLTS is able to perform the bi-directional insertion loss measurement with multiple wavelengths together with other parameters such as optical return loss and distance. OLTS shall be used in pair and required to be placed at both ends. Details of the test procedure using OLTS is explained in TIA-568B or TIA/TSB 140. The test setup is as shown in Figure 58.

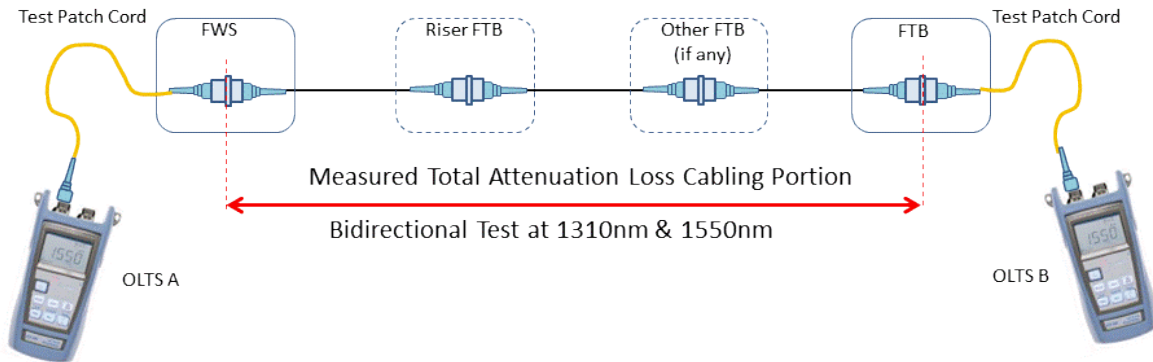

Figure 58. OLTS testing method

Before performing any test, both OLTS require a reference using the test patch cord to reset the connection. A high quality of test patch cord shall be used to get the accurate measurement.

6.8.2 Optical Time Domain Reflectometer (OTDR) test method

OTDR is a single ended measurement which is able to provide a total insertion loss, every event loss, distance, bi-directional result and ORL through a single measurement. Below is the items that should be consider by using the OTRD measurement:

- a) To obtain the accurate measurement, open end side shall be closed properly to avoid entering of the light that may contribute to the false light reflection to the test environment.
- b) To measure the first connector that connected to the test patch cord, a minimum of 10 m dummy fibre shall be used between OTDR and the test adaptor. However, to get a better result the longer dummy fibre, i.e. 100 m length is recommended to be used.
- c) At the open end side, another minimum of 10 m length of dummy fibre also needs to be used to obtain the accurate measurement of the last connector.
- d) A high quality of test patch cord shall be used to get the accurate measurement.

OTDR can provide each event measurement in the tested network and should be used during troubleshooting process. The sample test setup for OTDR measurement is as shown in Figure 59 below which to add dummy patch cord at the end.

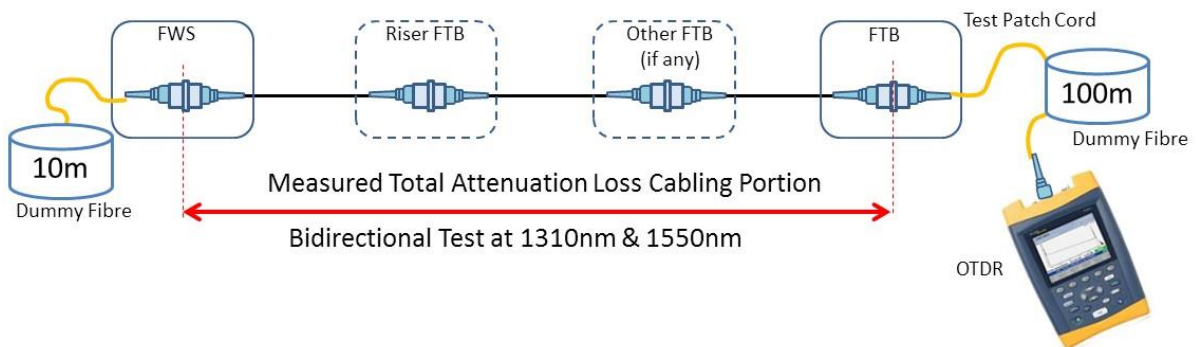

Figure 59. Optical Time Domain Reflectometer (OTDR) testing method

MCMC MTSFB TC G024:2020

6.8.3 Power meter and light source test method

Power meter and light source is a single ended insertion loss measurement method and is able to provide the total insertion loss only.

To obtain the bi-directional result, both test equipment need to be swapped and re-performed the test. The test setup shall follow as shown in Figure 60 below.

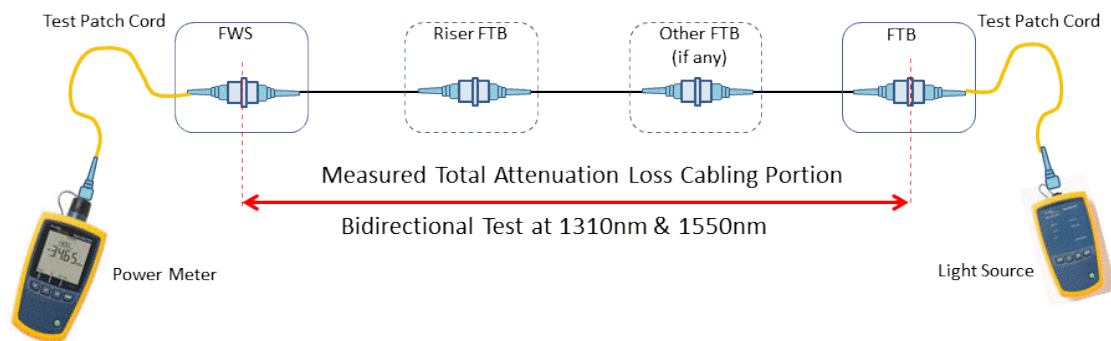

Figure 60. Power meter and light source testing method

Before performing any test, reference process using test patch cord is needed to reset the connection between power meter and light source. A high quality of test patch cord shall be used to get the accurate measurement.

6.8.4 Test result

Test result shall be provided to NFP during acceptance procedure. All results presented to NFP shall meet all the minimum requirements.

Test results are recommended to be printed in test equipment original version with the information of total bi-directional insertion Loss at 1310 wavelength.

The sample of recommended test results format is as shown in Table15 below.

Table 15. Sample of recommended test results format

Building name	Seri Pinang Condominium						
Vertical cable no.	FV001						
FTB rack no.	Rack 1						
FTB sub-rack no.	Sub-rack 1						
Test item			Insertion loss		Optical return loss - optional		
Test direction			Downstream	Upstream	Downstream	Upstream	
Rise FTB adaptor no.	Premise unit no.	Floor no.	1310 nm (dB)	1310 nm (dB)	1310 nm (dB)	1310 nm (dB)	Distance (m)
No. 1	A-1-01	1	1.1	1.1	33	33	100
No. 2	A-1-02	1	1.1	1.1	34	34	110
No. 3	A-1-03	1	1	1	36	36	120
No. 4	A-1-04	1	0.9	0.9	34	34	130
No. 5	A-2-01	2	1.1	1.1	34	34	100
No. 6	A-2-02	2	1.1	1.1	35	35	110

Table 15. Sample of recommended test results format *(continued)*

Rise FTB adaptor no.	Premise unit no.	Floor no.	1310 nm (dB)	1310 nm (dB)	1310 nm (dB)	1310 nm (dB)	Distance (m)
No. 7	A-2-03	2	1	1	34	34	120
No. 8	A-2-04	2	0.9	0.9	34	34	130
Remarks							
Tester							
Verified by NFP representative name							

NFP shall perform a random sampling test to ensure the test results submitted by property developer are correctly captured. The sampling tests shall be done by the property developer during the acceptance procedure with the witness of NFP's representative.

6.8.5 Test equipment calibration

All the test equipment and related tool shall be calibrated according to manufacturer specification and the calibration record shall be presented during acceptance procedure. It is to ensure all test equipment and tools are in the best condition to be used for any measurement.

6.9 Certification of the material

All materials used by property developer related to any material specified in this document shall be certified by MCMC's registered certifying agency or NFP according to the specified standards. The type approval certificates shall be presented during acceptance procedure. For any development that fails to present the certification, it shall be rejected by NFP during acceptance procedure. Certification validity shall be as specified in the certificate.

7. Infrastructure and cabling acceptance procedure

7.1.1 NFP infrastructure connection request

Property developer or premises owner shall engage with selected NFP for infrastructure connection 90 days before service installation target date.

Upon the completion of the infrastructure and cabling, property developer or premises owner shall submit the service application form to NFP 14 days before service installation target date.

7.1.2 Documentation during acceptance procedure

Property developer or premises owner is required to submit all of documents as listed below during acceptance procedure:

- a) Acceptance checklist endorsed by consultant or contractor;
- b) Internal infrastructure floor plan;
- c) External infrastructure development plan;
- d) As built and cabling schematic line diagram;
- e) Fibre core assignment - sample as shown in Annex E;
- f) Cabling test results;

MCMC MTSFB TC G024:2020

- g) calibration certificate of test equipment; and
- h) Registered certifying agency or NFP's type approval certificate of each material used.

During the acceptance process, if necessary, NFP will issue Certificate of Acceptance if all of the requirements are fulfilled according to the specifications.

7.1.3 Infrastructure handover

Selected NFP shall have a proper handover agreement of the infrastructure within the related development area. Details of the agreement shall be mutually agreed between NFP and property developer.

7.1.4 Rules and regulations

Property developer shall comply with all rules and regulations as listed below:

- a) The property developer shall hire Occupational Safety, Health and Environment (OSHE) and CIDB certified contractor for all the communications infrastructure and cabling works for the development areas.
- b) Both parties shall adhere to the agreed acceptance procedure.
- c) The property developer to prepare all the documentations required for all the processes for the acceptance procedure.
- d) The property developer to prepare all the necessary tools and test equipment.
- e) All the relevant officials/ personnel are required to be present during the acceptance procedure.
- f) The acceptance procedures should be performed and completed on the same day.
- g) The property developer to ensure all relevant permits are obtained and to be in compliance with all the relevant safety requirements.
- h) The acceptance procedure is to be performed once the development progress is 95 % completed.
- i) All the non-complied items during acceptance procedure shall be rectified by property developer. Property developer shall request a new acceptance test procedure to verify the rectified items.
- j) The NFP shall issue certification of acceptance (COA) upon completion of acceptance procedure.

8. Safety and precaution

8.1 Configuration of safety device

Safety facilities for construction projects shall adhere to the NFP's guidelines issued by the relevant parties of NFP and/or any requirements issued by the relevant authorities. The use of safety equipment is required during the installation and handling of optical fibre cable, for example gloves and safety glasses.

8.2 Other safety elements

Construction environment, safety requirements and safety condition are as follows:

- a) Firefighting apparatus and material shall be prepared at the job location (i.e. smoke induction, temperature induction and other alarm device) and shall be in good working condition.
- b) Power supply sockets for different voltages in the machine room should have clear identification.
- c) Hazardous goods such as inflammables and explosives and pigtailed are forbidden in machine room.
- d) Reserved holes in the building plate should be configured with safety cover.
- e) Additional safety device should be added to the project to ensure the safety of construction.

Annex A
(normative)

Fibre Termination Box (FTB) specifications

- a) The FTB shall be suitable for attachment to inside or outside wall of a building.
- b) The material shall be able to protect the component against harsh, high heat and humidity environment. The FTB shall be designed and conforms to IP44 of IEC 60529 Ed. 2.1 standards or better for indoor application and IP54 of IEC 60529 Ed. 2.1 standards or better for outdoor application.
- c) Evidence (such as certificate, letter of conformance, etc.) from MCMC's registered certifying agency or authorized body shall be provided during approval process.
- d) The FTB shall be suitable for 19-inch rack-mount and/or wall mounted. The offered FTB shall complete with its respective mounting kits.
- e) The framework of the high density and medium density FTB shall be fabricated from electro-galvanised steel or rust proof steel plating of thickness not less than 2.0 mm and the design shall conform to ISO 2081 or other recognized standards.
- f) The framework of the premises FTB and FWS shall be plastic injection moulded or thermoplastic and made of fire-retardant material. All the plastic material shall have a rating of V-1 or better as determined by Underwriters Laboratories' UL94 standards.
- g) The FTB shall be designed with built-in splitter or without splitter.
- h) All edges shall be rounded.
- i) Total weight of the FTB including full accessories shall be suitable for wall mounting.
- j) For high density FTB, the maximum overall dimension shall be 406 mm (H) x 457 mm (W) x 152 mm (D).
- k) For customer premises FTB, the maximum overall dimension shall be 203 mm (H) x 127 mm (W) x 38 mm (D).
- l) The property developer shall propose separate sizes and capacity to provide cable management and connection for high, medium, low and individual premises fibre installation including FWS.
- m) The property developer shall furnish detailed specification and characteristic of the various sizes of the FTB and FWS offered during the submission of proposal for evaluation.
- n) The property developer shall submit proposed technical drawings complete with dimensions for the product offered.
- o) The FTB shall consist of moulded inner fibre slack storage, sleeve holder and integral positive lock strain relief for cable and other accessories deem necessary.
- p) The FTB design shall have suitable splice tray and cable management area to provide for minimum bending radius and for storage ruggedized splitter pigtails.

MCMC MTSFB TC G024:2020

- q) Suitable number of splices organized trays or splice trays shall be provided in the splice compartment. The splice tray shall be of cartridge or cassette types that are stackable and flappable or able to be opened sideways.
- r) The number of trays and other appropriate accessories provided shall suit the maximum number of cores of the fibres intended to be installed. The splice tray shall comply with GR-771.
- s) The FTB shall have pre-assembled plates with Standard Connector/Ultra Polished Connector (SC/UPC) or Standard Connector/Angle Polished Connector (SC/APC) type of adaptor coupling for fibre patching.
- t) It shall be designed with two (2) physically separated compartments to isolate the incoming cable (capable of accommodating splitter where needed) from the drop fibre compartment.
- u) The door opening shall be designed for suitable operation in confined space.
- v) The FTB shall be provided with various sizes of cable entries at both top and bottom. All cable entries shall be provided with rubber grommets to protect the cable and prevent pest and dirt entry.
- w) The rubber grommets shall have suitable guides for different cable sizes to permits pass through of additional fibres.
- x) The FTB design shall be economical, effective, robust and compact to provide access point for drop fibre and internal fibre.
- y) Each FTB shall be provided with a table or label card for circuit identification purpose. The table shall be printed on durable material in such a manner as to be permanently legible, protected by an acrylic pocket and properly displayed on the inside cover of the FTB.
- z) Approved laser caution signs as per IEC 60825-1 Ed 2.0 requirements shall be provided as standard for every FTB.
- aa) The termination offered and its associated hardware shall be commercially available (in current production) and already been commercially deployed. Any prototype and unproven system shall be disqualified. Property developer to submit evidence to prove the systems are field proven and in current production.
- bb) An inventory list containing lists of components or parts supplied and operation and installation manual shall be provided with each FTB.

Annex B
(normative)

Specification for in-building fibre cable

B.1 In-building fibre cable

- a) In-building fibre cable shall be single-mode in-building fibre reinforced with FRP for indoor applications.
- b) Fibre characteristic are as follows:
 - i) The fibre characteristic shall be in accordance with the ITU-T G.657A (Bend Insensitive Fibre $\leq 15\text{mm}$ bending radius).
 - ii) Macro bending loss performance at 1550 nm and 1625 nm regions shall be in accordance with ITU-T G.657 class A (12/2006) Clause 7.
 - iii) In order to ensure low loss operation at 1550 and 1625nm regions, the increase in loss for 10 turns of the loosely wound fibre using a mandrel with 15mm radius should be 0.5dB.
 - iv) Maximum loss at 1550nm shall be 0.25dB and at 1625nm shall be 1.0dB
- c) Proof stress shall not be less than 0.69 Gpa.
- d) Chromatic dispersion coefficient shall be as follow:
 - i) Zero dispersion slope shall be less than and equal to $0.092 \text{ ps/nm}^2\text{km}$.
 - ii) Zero dispersion wavelength shall range from 1300 nm to 1324 nm
- e) The attenuation coefficient of the Fibre shall be as follows:
 - i) Maximum 0.35 dB/km - from 1310 nm to 1625 nm regions.
 - ii) Maximum 0.4 dB/km in the $1383 \text{ nm} \pm 3 \text{ nm}$ region.
 - iii) Maximum 0.3 dB/km in the 1550 nm region.
- f) PMD Coefficient - PMD link design value shall be maximum of $0.2 \text{ ps}/\sqrt{\text{km}}$ in accordance with ITU-T Recommendation G.657 class A (12/2006) Clause 7.
- g) Optical fibre shall be placed in between two strength members. The construction of the in-building drop fibre shall be 1 fibre or 2 fibre cores.
- h) The colour coding shall be as Table A.1 below:

Table A.1. In-building fibre cable colour coding

Number	Fibre
1	Blue
2	Yellow

- i) The cable shall contain FRP material as cable strength member. Nominal diameter for FRP shall be 0.4 mm.
- j) The in-building drop fibres nominal outer diameter shall be 3.1 mm x 2.0 mm.
- k) The in-building drop fibres shall be sheathed with polyethylene and flame-retardant characteristic. Performance on oxygen index of sheath shall be ≥ 27 .

B.2 The sheath

- a) The sheath shall be ivory colour and shall not promote the growth of fungus.
- b) The sheath around the cable and bearer wire shall be free from pinholes, joints, mended places and other defects and able to provide adequate mechanical protection against impact and crushing.
- c) The sheath shall be marked with the manufacturer's name, sequential meter, month and year of manufacturer, fibre count and fibre type.
- d) The marking shall be in contrasting colour to the cable sheath. The preferred marking colour will be white.
- e) The general cable performance test of the offered in-building drop fibre shall be in accordance with ANSI/ICEA S-104-696 or equivalent to other international standards. It shall be verified through suitable test.
- f) The tensile strength of the in-building cable shall be in excess of 80 N. At this load, no residual fibre elongation and the increase in attenuation shall be less than 0.05 dB/km.

B.3 Bend test

- a) The cable shall be unwound and ten (10) turns shall be wrapped in a close helix around a mandrel of radius 15 mm.
- b) The turns shall be applied at a uniform rate of one revolution in about 5 seconds and with sufficient tension to ensure that the specimen contours the mandrel.
- c) The turns shall be then unwound and the cycle repeated 3 times. Finally, measurement shall show no change to the optical characteristics of the cable.

Annex C
(normative)

Specification for blown fibre - alternative in-building fibre cabling system

- a) In-building fibre cable shall be single-mode in-building fibre using blown fibre distribution system for in-building applications.
- b) Fibre characteristic shall be in accordance with ITU-T G.657A (bend insensitive fibre ≤ 15 mm bending radius).
- c) Macro Bending Loss shall comply to below:
 - i) The loss performance at 1550 nm and 1625 nm regions shall be in accordance with ITU-T Recommendation G.657 class A (12/2006) Clause 7.
 - ii) In order to ensure low loss operation at 1550 nm and 1625 nm regions, the increase in loss for 10 turns of the loosely wound fibre using a mandrel with 15mm radius should be 0.5 dB.
 - iii) Maximum loss at 1550nm shall be 0.25 dB and at 1625 nm shall be 1.0 dB.
- d) Proof stress shall not be less than 0.69 Gpa.
- e) Chromatic dispersion coefficient shall be as follow:
 - i) Zero Dispersion Slope shall be less than and equal to 0.092 ps/nm².km.
 - ii) Zero Dispersion Wavelength shall range from 1300 nm to 1324 nm.
- f) The attenuation coefficient of the fibre shall be as follows:
 - i) Maximum 0.4 dB/km – from 1310nm to 1625nm regions.
 - ii) Maximum 0.4 dB/km in the 1383 nm ± 3 nm region.
 - iii) Maximum 0.3 dB/km in the 1550 nm region.
- g) PMD coefficient - PMD link design value shall be maximum of 0.2 ps/ $\sqrt{\text{km}}$ in accordance with ITU-T Recommendation G.657 class A (12/2006) Clause 7.
- h) Optical fibre shall be placed within fibre micro ducts having properties such as:
 - i) Low Flammability;
 - ii) Low Smoke;
 - iii) Low Acid/Fume; and
 - iv) Low Halogen.
- i) The construction of the in-building fibre shall be 1 fibre or 2 fibre cores.
- j) The colour coding shall be as Table C.1 below:

Table C.1 Blown fibre cable colour coding

Number	Fibre
1	Blue
2	Yellow

Annex D
(normative)

Micro duct

D.1 Micro duct

- a) The micro ducts shall be numbered.
- b) The micro duct nominal outer diameter shall be 5 mm.
- c) The micro duct shall be constructed with polyethylene and flame-retardant characteristic. Performance on oxygen index of sheath shall be ≥ 27 .
- d) The micro duct shall be ivory colour and shall not promote the growth of fungus.
- e) The micro duct around the cable shall be free from pinholes, joints, mended places and other defects and able to provide adequate mechanical protection against impact and crushing.
- f) The micro duct shall be marked with the manufacturer's name, sequential meter, month and year of manufacturer, fibre count and fibre type.
- g) The marking shall be in contrasting colour to the micro duct. The preferred marking colour will be white.
- h) The general cable performance test of the offered in-building drop fibre shall be in accordance with ANSI/ICEA S-104-696 or equivalent to other international standards. It shall be verified through suitable test.
- i) Tensile strength -the tensile strength of the micro duct shall be in excess of 70 N.

D.2 Bend test

- a) The fibre shall be unwound and ten (10) turns shall be wrapped in a close helix around a mandrel of radius 15 mm.
- b) The turns shall be applied at a uniform rate of one revolution in about 5 seconds and with sufficient tension to ensure that the specimen contours the mandrel.
- c) The turns shall be then unwound and the cycle repeated 3 times.
- d) Finally measurement shall show no change to the optical characteristics of the cable.

Annex E
(informative)

Sample of core assignment

The sample core assignment as shown in Table E.1 below.

Table E.1. Sample of core assignment

FTB number		1													
FTB subrack		1													
FTB Port	Vertical Cable			FTB Port	Vertical Cable			FTB Port	Vertical Cable			FTB Port	Vertical Cable		
	Cable number	Core number	Cable number		Cable number	Core number	Cable number		Cable number	Core number	Cable number		Cable number	Core number	Cable number
1	FV0 01	1	101	13	FV0 01	13	201	25	FV0 01	25	301	37	FV0 01	37	Spare
2	FV0 01	2	101	14	FV0 01	14	201	26	FV0 01	26	301	38	FV0 01	38	Spare
3	FV0 01	3	102	15	FV0 01	15	202	27	FV0 01	27	302	39	FV0 01	39	Spare
4	FV0 01	4	102	16	FV0 01	16	202	28	FV0 01	28	302	40	FV0 01	40	Spare
5	FV0 01	5	103	17	FV0 01	17	203	29	FV0 01	29	303	41	FV0 01	41	Spare
6	FV0 01	6	103	18	FV0 01	18	203	30	FV0 01	30	303	42	FV0 01	42	Spare
7	FV0 01	7	104	19	FV0 01	19	204	31	FV0 01	31	304	43	FV0 01	43	Spare
8	FV0 01	8	104	20	FV0 01	20	204	32	FV0 01	32	304	44	FV0 01	44	Spare
9	FV0 01	9	105	21	FV0 01	21	205	33	FV0 01	33	305	45	FV0 01	45	Spare
10	FV0 01	10	105	22	FV0 01	22	205	34	FV0 01	34	305	46	FV0 01	46	Spare
11	FV0 01	11	106	23	FV0 01	23	206	35	FV0 01	35	306	47	FV0 01	47	Spare
12	FV0 01	12	106	24	FV0 01	24	206	36	FV0 01	36	306	48	FV0 01	48	Spare

MCMC MTSFB TC G024:2020

Table E.1. Sample of core assignment (continued)

FTB number		1													
FTB subrack		2													
FTB Port	Vertical Cable			FTB Port	Vertical Cable			FTB Port	Vertical Cable			FTB Port	Vertical Cable		
	Cable number	Core number	Cable number		Cable number	Core number	Cable number		Cable number	Core number	Cable number		Cable number	Core number	Cable number
1	FV0 02	1	401	13	FV0 02	13	501	25	FV0 02	25	601	37	FV0 02	37	Spare
2	FV0 02	2	401	14	FV0 02	14	501	26	FV0 02	26	601	38	FV0 02	38	Spare
3	FV0 02	3	402	15	FV0 02	15	502	27	FV0 02	27	602	39	FV0 02	39	Spare
4	FV0 02	4	402	16	FV0 02	16	502	28	FV0 02	28	602	40	FV0 02	40	Spare
5	FV0 02	5	403	17	FV0 02	17	503	29	FV0 02	29	603	41	FV0 02	41	Spare
6	FV0 02	6	403	18	FV0 02	18	503	30	FV0 02	30	603	42	FV0 02	42	Spare
7	FV0 02	7	404	19	FV0 02	19	504	31	FV0 02	31	604	43	FV0 02	43	Spare
8	FV0 02	8	404	20	FV0 02	20	504	32	FV0 02	32	604	44	FV0 02	44	Spare
9	FV0 02	9	405	21	FV0 02	21	505	33	FV0 02	33	605	45	FV0 02	45	Spare
10	FV0 02	10	405	22	FV0 02	22	505	34	FV0 02	34	605	46	FV0 02	46	Spare
11	FV0 02	11	406	23	FV0 02	23	506	35	FV0 02	35	606	47	FV0 02	47	Spare
12	FV0 02	12	406	24	FV0 02	24	506	36	FV0 02	36	606	48	FV0 02	48	Spare

Table E.1. Sample of core assignment (continued)

FTB number		1													
FTB subrack		3													
FTB Port	Vertical Cable			FTB Port	Vertical Cable			FTB Port	Vertical Cable			FTB Port	Vertical Cable		
	Cable number	Core number	Cable number		Cable number	Core number	Cable number		Cable number	Core number	Cable number		Cable number	Core number	Cable number
1	FV0 03	1	701	13	FV0 03	13	801	25	FV0 03	25	901	37	FV0 03	37	Spare
2	FV0 03	2	701	14	FV0 03	14	801	26	FV0 03	26	901	38	FV0 03	38	Spare
3	FV0 03	3	702	15	FV0 03	15	802	27	FV0 03	27	902	39	FV0 03	39	Spare
4	FV0 03	4	702	16	FV0 03	16	802	28	FV0 03	28	902	40	FV0 03	40	Spare
5	FV0 03	5	703	17	FV0 03	17	803	29	FV0 03	29	903	41	FV0 03	41	Spare
6	FV0 03	6	703	18	FV0 03	18	803	30	FV0 03	30	903	42	FV0 03	42	Spare
7	FV0 03	7	704	19	FV0 03	19	804	31	FV0 03	31	904	43	FV0 03	43	Spare
8	FV0 03	8	704	20	FV0 03	20	804	32	FV0 03	32	904	44	FV0 03	44	Spare
9	FV0 03	9	705	21	FV0 03	21	805	33	FV0 03	33	905	45	FV0 03	45	Spare
10	FV0 03	10	705	22	FV0 03	22	805	34	FV0 03	34	905	46	FV0 03	46	Spare
11	FV0 03	11	706	23	FV0 03	23	806	35	FV0 03	35	906	47	FV0 03	47	Spare
12	FV0 03	12	706	24	FV0 03	24	806	36	FV0 03	36	906	48	FV0 03	48	Spare

MCMC MTSFB TC G024:2020

Table E.1. Sample of core assignment (concluded)

FTB number		1														
FTB subrack		4														
FTB Port	Vertical Cable			FTB Port	Vertical Cable			FTB Port	Vertical Cable			FTB Port	Vertical Cable			
	Cable number	Core number	Unit number		Cable number	Core number	Unit number		Cable number	Core number	Unit number		Cable number	Core number	Unit number	
1	FV0 04	1	100 1	13	FV0 04	13	110 1	25	FV0 04	25	120 1	37	FV0 04	37	Spare	
2	FV0 04	2	100 1	14	FV0 04	14	110 1	26	FV0 04	26	120 1	38	FV0 04	38	Spare	
3	FV0 04	3	100 2	15	FV0 04	15	110 2	27	FV0 04	27	120 2	39	FV0 04	39	Spare	
4	FV0 04	4	100 2	16	FV0 04	16	110 2	28	FV0 04	28	120 2	40	FV0 04	40	Spare	
5	FV0 04	5	100 3	17	FV0 04	17	110 3	29	FV0 04	29	120 3	41	FV0 04	41	Spare	
6	FV0 04	6	100 3	18	FV0 04	18	110 3	30	FV0 04	30	120 3	42	FV0 04	42	Spare	
7	FV0 04	7	100 4	19	FV0 04	19	110 4	31	FV0 04	31	120 4	43	FV0 04	43	Spare	
8	FV0 04	8	100 4	20	FV0 04	20	110 4	32	FV0 04	32	120 4	44	FV0 04	44	Spare	
9	FV0 04	9	100 5	21	FV0 04	21	110 5	33	FV0 04	33	120 5	45	FV0 04	45	Spare	
10	FV0 04	10	100 5	22	FV0 04	22	110 5	34	FV0 04	34	120 5	46	FV0 04	46	Spare	
11	FV0 04	11	100 6	23	FV0 04	23	110 6	35	FV0 04	35	120 6	47	FV0 04	47	Spare	
12	FV0 04	12	100 6	24	FV0 04	24	110 6	36	FV0 04	36	120 6	48	FV0 04	48	Spare	

Acknowledgements

Members of the Fixed Network Facility Sub-Working Group

Mr Mohd Yusairi Abu Hassan (Chairman)	Telekom Malaysia Berhad
Mr Zulkefli Zabri (Vice Chairman)	Maxis Bhd
Mr Sufian Sulaiman (Secretary)	Telekom Malaysia Berhad
Mr Muhaimin Mat Salleh/ Mr Mohamad Hafiz Halal (Secretariat)	Malaysian Technical Standards Forum Bhd
Mr Hairul Razi Hamdan	Core MTX Sdn Bhd
Mr Ahmad Fadzly Misron	Digi Telecommunications Sdn Bhd
Mr Jaizan Zuki	edotco Group Sdn Bhd
Mr Mokhtar Daud	Malaysian Digital Economy Corporation
Mr Mohd Nazim Mahmud/ Mr Md Shaiful Zainal	Maxis Bhd
Mr See Boon Leng/ Mr Leong Woon Min/ Mr Ivan Leong Yoon Khong	Redsun Engineering Sdn Bhd
Mr Najib Fadil Mohd Bisri/ Mr Mohd Razman Rusli/ Mr Mohd Haslishah Jalil/ Mr Md Rawi Abu/ Mr Mohd Ariff Arifen/ Mr Noor Fadlee Muhammad Hairi/ Mr Mohd Syahrir Ribuan	Telekom Malaysia Berhad
Mr Abdulhadi Wahid/ Mr Mohd Faiz Hasmi	TIME dotcom Bhd
Mr Roslan Mohd Kasim	U Mobile Sdn Bhd
Ir Ts Dr Mohd Fauzi Ab Rahman/ Ir Dr Anas Abdul Latiff/ Mr Muhammad Taufiq Ahmad/ Mr Mohd Adzimnuddin Mohd Nor Azami	Universiti Teknikal Malaysia Melaka

By invitation:

Mr Husni Azam Yusof/

Allo Technology Sdn Bhd

Mr Jeysudason

Mr Than Kok How

Emtelle Asia Pacific (M) Sdn Bhd

Mr Mohd Hafiz Ramli/

Dewan Bandaraya Kuala Lumpur

Mr Affendy Ariffin

Mr Chandiramohan Ranjithan/

Jabatan Kerja Raya Malaysia

Ms Hazmatul Farha Hamzah/

Mr Muhammad Aidil Razak

Mr Zaharin Mohd Nadzri

SMARTSEL Sdn Bhd

Mr Kuo Hai Ann

Zettabits Technologies (M) Sdn Bhd