

TECHNICAL CODE

TECHNICAL STANDARD AND INFRASTRUCTURE REQUIREMENTS

FIXED NETWORK INFRASTRUCTURE FOR SIMPLE DEVELOPMENT PROPERTIES

Developed by



Registered by



Registered date:

5 October 2016

MCMC MTSFB TC G006:2016

DEVELOPMENT OF TECHNICAL CODES

The Communications and Multimedia Act 1998 ('the Act') provides for Technical Standards Forum designated under section 184 of the Act or the Malaysian Communications and Multimedia Commission ('the Commission') to prepare a technical code. The technical code prepared pursuant to section 185 of the Act shall consist of, at least, the requirement for network interoperability and the promotion of safety of network facilities.

Section 96 of the Act also provides for the Commission to determine a technical code in accordance with section 55 of the Act if the technical code is not developed under an applicable provision of the Act and it is unlikely to be developed by the Technical Standards Forum within a reasonable time.

In exercise of the power conferred by section 184 of the Act, the Commission has designated the Malaysian Technical Standards Forum Bhd ('MTSFB') as a Technical Standards Forum which is obligated, among others, to prepare the technical code under section 185 of the Act.

A technical code prepared in accordance with section 185 shall not be effective until it is registered by the Commission pursuant to section 95 of the Act.

For further information on the technical code, please contact:

Malaysian Communications and Multimedia Commission (MCMC)

MCMC Tower 1
Jalan Impact, Cyber 6
63000 Cyberjaya
Selangor Darul Ehsan
MALAYSIA

Tel: +60 3 8688 8000
Fax: +60 3 8688 1000
<http://www.skmm.gov.my>

OR

Malaysian Technical Standards Forum Bhd (MTSFB)

Malaysian Communications and Multimedia Commission (MCMC)
Off Persiaran Multimedia
Jalan Impact
63000 Cyberjaya
Selangor Darul Ehsan
MALAYSIA

Tel: +60 3 8322 1441/1551
Fax: +60 3 8322 0115
<http://www.mtsfb.org.my>

CONTENTS

	Page
Committee Representation	v
FOREWORD	vi
1. Scope.....	1
2. Normative references	1
3. Abbreviations and Definitions	1
3.1 Abbreviations	1
3.2 Definitions	2
4. Simple Development Criteria.....	2
5. Building types	2
6. Type of services.....	3
6.1 Basic fixed telecommunication services	3
6.2 Optional fixed telecommunication services	3
7. Telecommunication infrastructure requirement	3
7.1 General	3
7.2 Infrastructure demarcation.....	3
7.3 Manhole and Underground Duct.....	5
7.4 Underground Duct Route	6
7.5 Premise Lead-In Duct and Building Pit.....	7
7.6 Pole Access	8
7.7 Telecommunication Room (TR).....	8
7.8 Telecommunication Closet (TC)	8
7.9 Riser.....	9
8. In Building Fibre Cabling	9
8.1 Cabling Demarcation Point	9
8.2 Termination Point (TP) - Fibre Termination Box (FTB).....	10
8.3 Fibre Wall Socket (FWS)	11
8.4 Internal Fibre Cable	11
8.5 Cabling Insertion Loss (IL).....	13
8.6 Cabling Design.....	13
9. Structured cabling.....	14
9.1 Termination Point (TP).....	14
9.2 Structured cable.....	15
9.3 Telecommunication Outlet (TO).....	15
10. Cabling test.....	17
10.1 UTP cabling test.....	17
10.2 Wiremap Test.....	17
10.3 Performance Test	18
10.4 UTP Testing Procedures	18
10.5 Insulation Resistance (IR) test.....	19
10.6 Conductor Resistance (CR) test.....	20
10.7 Fibre Cabling test.....	21
11. Infrastructure and cabling acceptance procedure	22

MCMC MTSFB TC G006:2016

11.1	Timeline to provide services	22
11.2	Service application process flow.....	22
11.3	Documentation.....	23
	Acknowledgements	37

Figures

1	Criteria for Simple Development Properties	2
2	Infrastructure Demarcation Point.....	4
3	Manhole and Underground Duct Layout	5
4	Design of duct connection under drain	6
5	Design of duct connection through drain	7
6	Lead-In Duct and Building Pit Design.....	7
7	NFP connection via Pole	8
8	Demarcation Point between Developer and NFP.....	10
9	Sample of two (2) cores FTB.....	10
10	Sample of FWS.....	11
11	Structure of Internal Fibre Cable	12
12	Fibre cabling design	13
13	Structured cabling design – without fibre cabling	14
14	Structured cabling connection diagram	15
15	TO socket type.....	16
16	Pair Assignment for T568B.....	16
17	Sample of Structured Cabling SLD Diagram	17
18	Wiremap Tester	18
19	Permanent link testing configuration	19
20	Insulation Resistance (IR) test connection	20
21	Conductor Resistance (CR) test.....	20
22	Insertion Loss (IL) setup	21

Tables

1	Basic fixed telecommunication services	3
2	Manhole Size	6
3	Telecommunications Closet dimension	9
4	ITU-TG.657 category A attributes.....	12
5	Cabling Power Attenuation Loss for SDU – pole type.....	13
6	Standard resistance for single copper conductors	21
7	Infrastructure approval and service activation process	22
D1	Insulated conductors - dimensions and resistance	33
D2	Colour scheme for pairs	33
D3	Colour of binder tapes	34

Annexes

A	Normative references	24
B	Fibre Termination Box (FTB) and Fibre Wall Socket (FWS) Specifications.....	25
C	Technical Specification for 10 Pair Disconnection Module	27
D	Copper Cable Specification	33
E	Insertion Loss Test Result	35
F	Sample of Development Plan	36

Acknowledgements

MCMC MTSFB TC G006:2016

Committee Representation

Fixed Network Facilities Working Group (FNF WG) under the Malaysian Technical Standards Forum Bhd (MTSFB) which developed this Technical Code consists of representatives from the following organizations:

Jaring Communication Sdn. Bhd

Maxis Communication Sdn. Bhd

Telekom Malaysia Berhad

Time dotCom Berhad

FOREWORD

This technical code for the Technical Standard and Infrastructure Requirements for Simple Development Properties ('Technical Code') was developed pursuant to section 185 of the Act 588 by the Malaysian Technical Standards Forum Bhd ('MTSFB') via its Fixed Network Facilities Working Group (FNF WG)

The Fixed Network Facilities (FNF) forms a part of the Technical Standards and Infrastructure Requirements (TSIR) document which serves as guidelines and standards in support of the Uniform Building By-Laws (UBBL). This document as a sub-document of TSIR specifically develops for Simple Development Properties that only require a basic telecommunication infrastructure. The document was prepared with the common understanding and agreement among the Fixed Network Providers' representatives in Malaysia.

In the context of meeting the needs of telecommunication (fixed network services) users, TSIR addresses the technical system and infrastructure requirements necessary for having the fixed network distribution system equipped in the building. This is important in view of Fixed Network Services which are used as a medium for delivery the basic telecommunication service which are the Telephony and Multi Broadband Services to the public / customers.

As stated above, the Fixed Network Facilities in the TSIR for Simple Development Properties document covers two primary objectives:

- a) It outlines the infrastructure requirements (for the purpose of setting up a common and integrated fixed network distribution system) to consulting engineers, Developers, owners and other responsible parties for the provisions to be made available in the simple development category buildings.
- b) It also provides the minimum technical specifications necessary for the Fixed Network Telephony and Multi broadband distribution system to function as required in simple development buildings.

This Technical Code shall continue to be valid and effective until reviewed or cancelled.

**TECHNICAL STANDARD AND INFRASTRUCTURE REQUIREMENTS FOR
SIMPLE DEVELOPMENT PROPERTIES**

1. Scope

This technical code covers the technical standards and infrastructure requirements for the provision of fixed telecommunication services for Simple Development Properties.

The technical standards and infrastructure requirements for other developments shall follow the requirements specified in *MTSFB 008, 2005 (Revision 1) - Technical Standard and Infrastructure Requirements (TSIR) Part 1: Fixed Network Infrastructure*.

2. Normative references

The following normative references are indispensable for the application of this technical code. For dated references, only the edition cited applies. For undated references, the latest edition of the normative references (including any amendments) applies.

See Annex A.

3. Abbreviations and Definitions

3.1 Abbreviations

For the purpose of this Technical Code, the following abbreviation applies.

ACR	Attenuation to Crosstalk Ratio
BS	British Standard
CPE	Customer Premise Equipment
CR	Conductor Resistance
DB	Distribution Box
ELFEXT	Equal Level Far End Crosstalk
FTB	Fibre Termination Box
FWS	Fibre Wall Socket
GI pipe	Galvanized Iron Pipe
IDC	Insulation Displacement Connection
IEC	International Electrotechnical Commission
IL	Insertion Loss
IP	International Protection Rating, also called the Ingress Protection Rating
IR	Insulation Resistance
NEXT	Near End Crosstalk
NFP	Network Facilities Provider
PVC	Poly Vinyl Chloride
TC	Telecommunication Closet
TO	Telecommunication Outlet
TP	Termination Point
TR	Telecommunication Room
UTP	Unshielded Twisted Pair

3.2 Definitions

For the purposes of this Technical Code, the following definition applies

Developer	Properties Developer or Premise Owner whose build the properties
Premise Owner	Owner or responsible person / bodied of the premise

4. Simple Development Criteria

Simple Development Properties shall be limited to commercial or public properties and shall meet the following criteria.

- a) Size – the land size shall be less than 2 acres and the building built-up shall not exceed 1 acre (4046.9m²);
- b) Telecommunication infrastructure
 - i. Termination Point (TP) shall be located not higher than the second (2nd) floor and shall not exceed 6m (in height) from the ground;
 - ii. The distance between the linked up manhole to TP shall not exceed 150m; and
- c) Telecommunication service - The fixed voice service shall not exceed ten (10) lines and the fixed broadband service shall not exceed one (1) termination port.

The above criteria are illustrated in Figure 1 below.

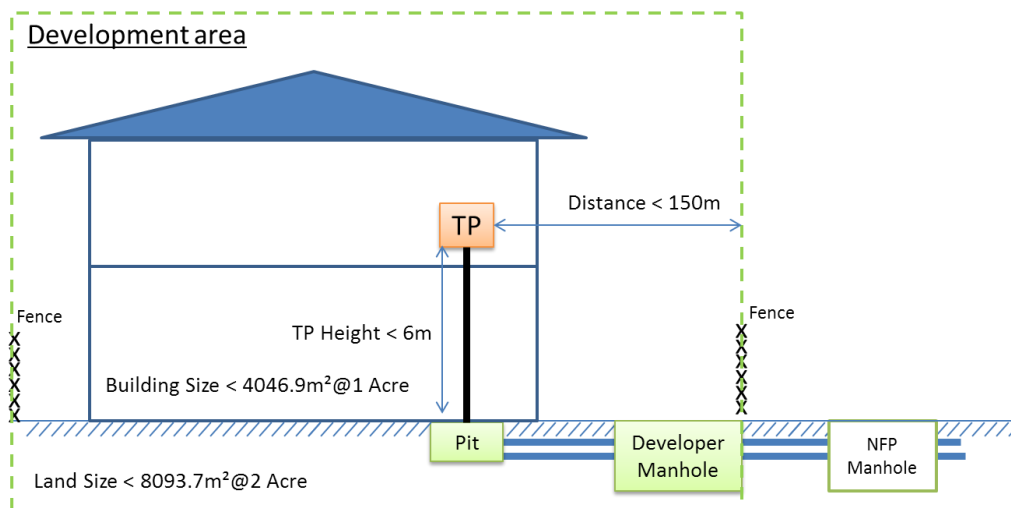

Figure 1. Criteria for Simple Development Properties

5. Building types

The typical buildings types, but not limited to, are as listed below:

- a) Warehouse
- b) Factory
- c) Petrol station
- d) Single outlet shop/restaurant
- e) Showroom
- f) Community hall
- g) Worship house

MCMC MTSFB TC G006:2016

6. Type of services

6.1 Basic fixed telecommunication services

The basic fixed telecommunication services that shall be supported by the infrastructure for Simple Development Properties are as listed in Table 1.

Table 1. Basic fixed telecommunication services

No.	Services	Type of infrastructure
1	Voice (Plain Old Telephone Service (POTS) or Integrated Services Digital Network (ISDN))	Copper Infrastructure - 10 pairs per unit of development
2	Broadband	Fibre Infrastructure - 1 termination point with 2 cores of optical fibre cables per unit of development

The Developer shall provide either fibre or copper infrastructure based on recommendation from NFP. Developer may however provide both types of cabling. The activation and selection of the infrastructure may be determined by the NFP based on the availability of network infrastructure.

6.2 Optional fixed telecommunication services

There are other fixed telecommunications services such as High Speed Broadband (HSBB), Internet Protocol Television (IPTV), Triple Play and Private Data Network (leased line) that may be supported by the infrastructure for Simple Development Properties. However, these services may only be provided subject to the agreement between Developer and NFP.

7. Telecommunication infrastructure requirement

7.1 General

Fixed telecommunication infrastructure refers to the infrastructure that will be required by NFP to offer the services for Simple Development Properties.

The types of infrastructure that shall be provided by the Developer are as below:

- a) Duct
- b) Manhole
- c) Termination Point (TP)
- d) Telecommunication Room (TR)
- e) Telecommunication Closet (TC)
- f) Trunking
- g) Riser

7.2 Infrastructure demarcation

The demarcation point between NFP and Developer is the nearest existing NFP's manhole that is linked to Developer's manhole as illustrated in Figure 2.

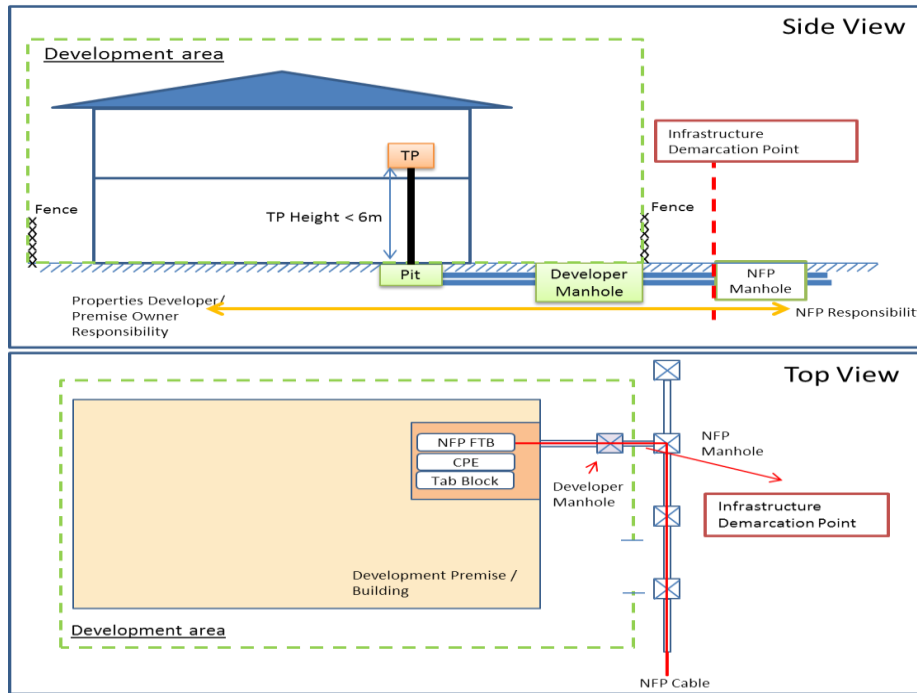

Figure 2. Infrastructure Demarcation Point

NFP's Manhole and all infrastructures towards NFP Central Office are under NFP's responsibility. The infrastructure from NFP's manhole towards the property area is under Developer's responsibility.

The infrastructure within the development area and any infrastructure required up to the demarcation point shall be provided by the Developer.

The maintenance of the infrastructure within the development area shall be under the responsibility of the Developer or premise owner.

The Developer shall be responsible at its own expense for the provision and maintenance of all the facilities within the development area, including but not limited to the facility records, cable trays, trunkings, underground duct and manholes, and for ensuring that they are in good serviceable condition and accessible to the NFP personnel at all times.

The Developer shall ensure at its own expense that adequate security measures are taken at the trunkings, underground duct and manholes to pre-empt trespassing by any unauthorized personnel. Under no circumstances should the trunkings, underground duct, manholes be used for any other purpose such as a store room.

The Developer or Premise Owner shall open and allow NFP to use the trunkings, underground duct and manholes for their deployment of telecommunication services.

All infrastructure materials and installation cost such as manholes, ducts and etc. up to the property line and within the Developer's premises will be borne by the Developer.

The infrastructure outside the development area up to the demarcation point shall be handed over and maintained by the first NFP appointed by the Developer. A proper hand over agreement shall be made between the appointed NFP and the Developer. The appointed NFP shall be responsible for maintaining the infrastructure and ensure the cleanliness of the space and facilities.

MCMC MTSFB TC G006:2016

7.3 Manhole and Underground Duct

The typical layout of manholes and underground ducts are illustrated in Figure 3 below:

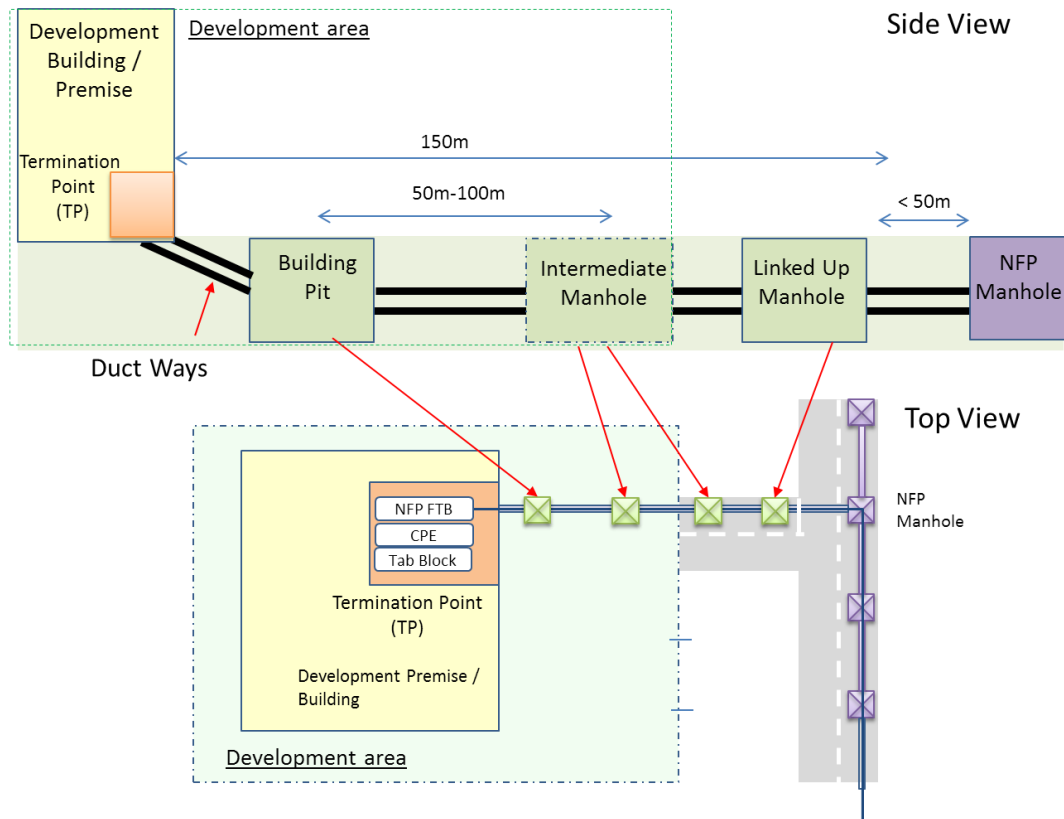

Figure 3. Manhole and Underground Duct Layout

The underground duct ways are required to connect NFP’s manhole and the internal infrastructure inside of the building. The maximum distance of underground infrastructure between linked up manhole and TP shall not exceed 150m. The distance between linked up manhole and NFP’s manhole shall not exceed 50m.

A minimum of two (2) duct ways shall be required to link between NFP’s manhole to TP. The minimum diameter of the duct shall be 100 mm.

The lifespan and capacity of the duct shall be able to support the needs of the service for the development area for at least 20 years. The Developer shall provide to the appointed NFP the certification issued by a certification body.

The duct ways shall be kept straight, without sharp bends and not obstructed. The minimum allowable bending radius is 20 times of the duct diameter.

The duct ways shall be laid by taking into consideration for easy and low maintenance costs. Whenever possible, the duct ways should not be laid under expensive paving.

The ducts shall be installed with “draw rope” for NFP to lay the cable inside the duct during service activation.

The Developer shall ensure that the constructed ducting system has a minimal risk from the natural disasters such as flood, earthquake etc. Whenever such condition cannot be avoided, the Developer shall undertake necessary measures to ensure the ducting system will always be in good condition.

The manholes shall be sited with particular attention to the followings:

- a) Minimal hazard to traffic and personnel;
- b) Adequate size to accommodate all equipment including repeater housings and cable joints; and
- c) Duct sectional length (distance between two manhole centres) is 50m to 100m wherever practicable.

The recommended manhole size is shown in Table 2 below.

Table 2: Manhole Size

No	Type of manhole	Size (L x W x D) (mm)	No. of duct ways	Application
1	JB30	960 x 960 x 740	2 Ways	Building Pit
2	JRC7	1280 x 985 x 955	2 Ways	Intermediate manhole
3	JC9	1815 x 900 x 1015	4 Ways	Intermediate or link up manhole
4	JC9C	2101 x 1400 x 1280	4 Ways	Connection to SDF Room

The Developer shall consult with the appointed NFP on the appropriate selection of number and design of the duct ways and manhole.

7.4 Underground Duct Route

The recommended underground duct route designs are as illustrated in Figure 4 and Figure 5. The design in Figure 4 is applicable if the depth of the drain is less than 450mm (1.5 feet).

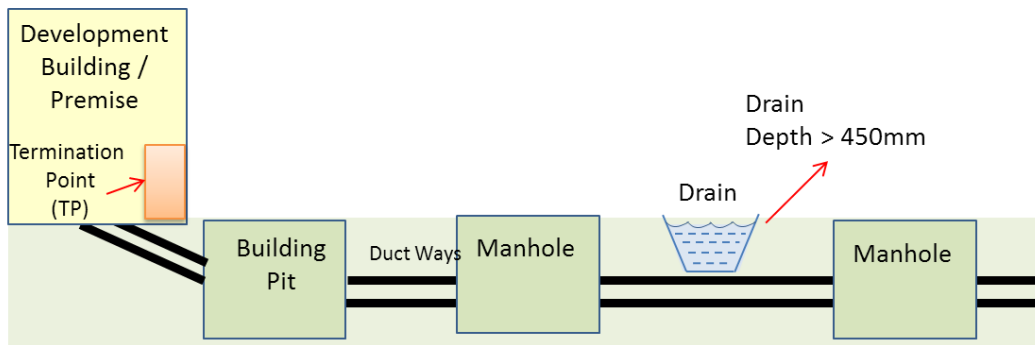

Figure 4. Design of duct connection under drain

If the depth of the drain is more than 450mm (1.5 feet), the recommended design is as shown in Figure 5. In this case, a GI pipe with a minimum diameter of 100mm shall be used as a duct. The GI pipe shall be placed above the water level to avoid trapping of garbage and disrupt water flow.

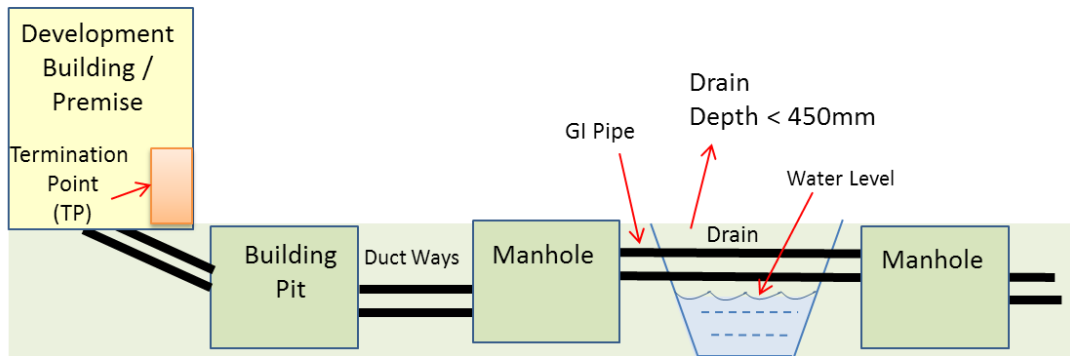

Figure 5. Design of duct connection through drain

7.5 Premise Lead-In Duct and Building Pit

Figure 6 show Premise Lead-In Duct and Building Pit design

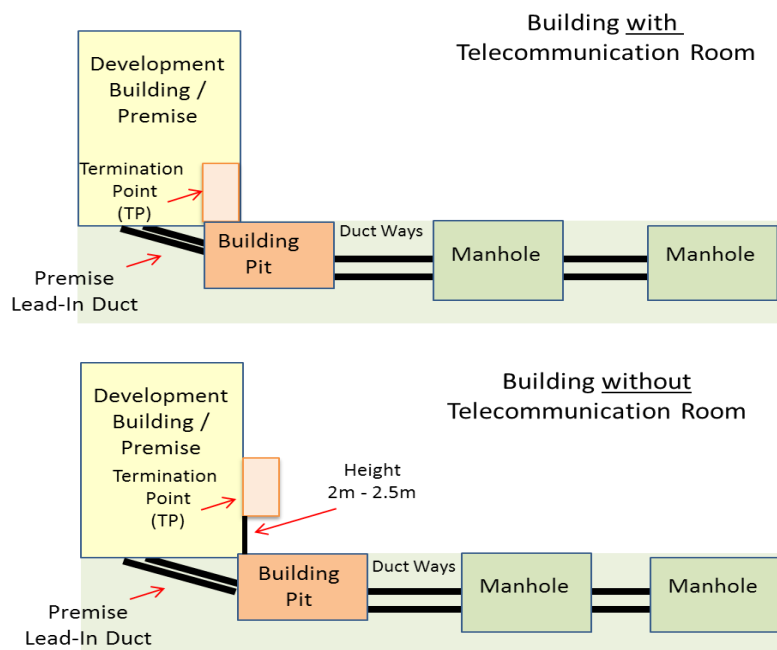

Figure 6. Lead-In Duct and Building Pit Design

Before entering the wall section of the premise, small pit with minimum size of 300mm (L) x 300mm (D) x 300mm (H) shall be provided for easy access during cable installation and maintenance work. The TP for fibre cabling is generally known as Fibre Termination Box (FTB).

For building with Telecommunication Room, the FTB shall be located on the wall inside the building Telecommunication Room. The recommended height of FTB is 2.0m to 2.5m from the floor.

For building without Telecommunication Room, the FTB shall be located on the wall outside of the building for easier service provisioning and maintenance work. The recommended height of FTB is 2.0m to 2.5m from the ground. Minimum of 2 ways duct shall be prepared by the Developer as Premise Lead-In Duct with 100mm diameter size

7.6 Pole Access

For cases where property feeds via pole, underground duct infrastructure is not required.

In general, the pole inside development area is recommended to be prepared by NFP according to NFP specification and planning guideline. NFP may request Properties Developer to provide it depending on the suitability and progress of the development project. Properties Developer shall consult with NFP for the Pole Specification, Type Approval and Planning and Installation Guideline.

For the case the distance from the nearest NFP pole to the development building is > 50m, NFP may place the pole inside the development area.

The demarcation point between Developer and NFP shall be at the FTB. The infrastructure from FTB, including the FTB, towards the property area and building is under Developer responsibility. The infrastructure from NFP's pole towards the property area is under Developer's responsibility.

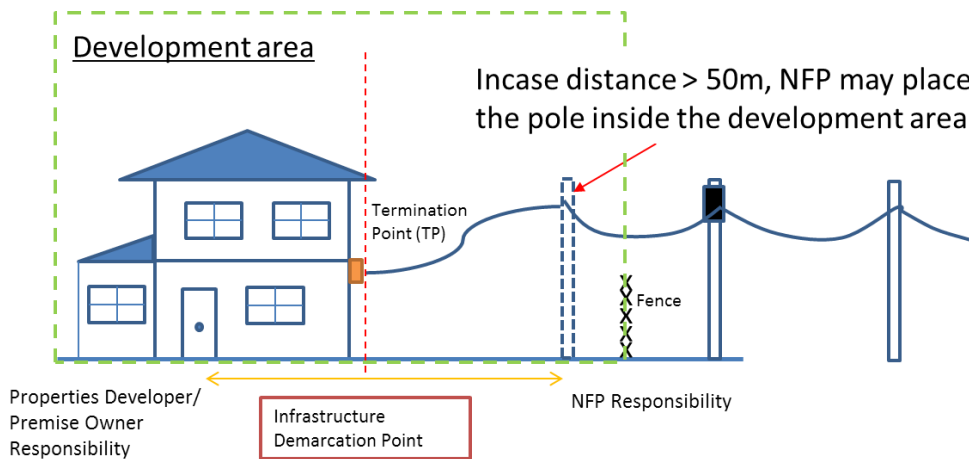

Figure 7. NFP connection via Pole

7.7 Telecommunication Room (TR)

The Developer shall dedicate a room with security lock to locate all Fixed Network equipment and cables, identified as the Telecommunication Room (TR).

The requirement for TR shall follow as explained in *MTSFB 008, 2005 (Revision 1) - Technical Standard and Infrastructure Requirements (TSIR) Part 1: Fixed Network Infrastructure*

7.8 Telecommunication Closet (TC)

TC is an option for TR which shall provide the same function which is to house the telecommunication facilities and elements for low scale building.

The TC must be of an appropriate size and height, safe, well-lit, flood-free and environmentally a protected area for equipment and personnel.

The Developer shall dedicate a room with security lock to locate all Fixed Network equipment and cables, identified as the "Telecommunications Closet".

The TC shall be placed on the ground-floor area and connected to the manhole and duct-way and should be located free from perceptible vibration. Ducting, sewage pipes, air condition pipes etc. shall not pass through the TC.

The recommended TC dimension is as shown in Table 3 below:

MCMC MTSFB TC G006:2016

Table 3. Telecommunications Closet dimension

Dimension (L x W x H) (m x m x m)	Door opening (W x D) (m x m)
1 x 1 x 1	2.5 x 1

The TC shall be provided with electrical AC supply from the utility supplies at a nominal of 415V, 3 phase, 4 wires, 50 Hz system or at a nominal voltage of 240V AC single-phase system with solidly earth system. The type of the TC shall be equipped with daylight type fluorescent lighting that can provide a minimum luminance of 300 Lux at floor level.

The room shall be fitted with a ventilation fan system capable of 30 air change/min, activated when the room temperature rises above 35°C.

There should be no opening in the TC except for the door, the ventilation and cabling ducts. The door dimension shall be 1m x 2.5m. All windows if any shall be shut and sealed along the frames to keep out water and dust and blind should be provided to avoid direct sunlight. Solid walls should be provided for heavy equipment mounting. The walls and ceiling should be of normal finishing or be painted with light-coloured vinyl emulsion or gloss paint.

Floor of the TC shall be of material that is easy to clean and not susceptible to accumulation of dust, flooring requirement is anti-static vinyl type mat and bonded to the earth bus bar. The room shall be flood free. A 150mm kerb across the doorway is required to prevent water from entering the room.

The clear ceiling height of TC shall not be less than 3m, so as to enable installation of equipment, cabinets and cabling.

7.9 Riser

The requirement for Riser shall follow as explained in *MTSFB 008, 2005 (Revision 1) - Technical Standard and Infrastructure Requirements (TSIR) Part 1: Fixed Network Infrastructure*

8. In Building Fibre Cabling

This section covers the requirement for cabling and its related elements inside the building from the Termination Point (TP) to the user's last point which is the Telecommunication Outlet.

All material used for the cabling shall be certified by MCMC registered certifying agency or the NFP. The compliance certificates shall be provided to the appointed NFP during service provisioning or infrastructure acceptance. The appointed NFP may refuse the service application if the certificates are not provided.

8.1 Cabling Demarcation Point

The cabling demarcation point is at TP as shown in Figure 8.

a) NFP Responsibilities

All the cabling from NFP Manhole toward the TP shall be provided by the appointed NFP. However after the service been provisioned to the premise, the responsibility to ensure the cabling is in good condition within the development area is under the Premise Owner. If the damage of the cabling is due to the poor maintenance or directly caused by the Premise Owner, NFP may transfer the restoration responsibility to the Premise Owner.

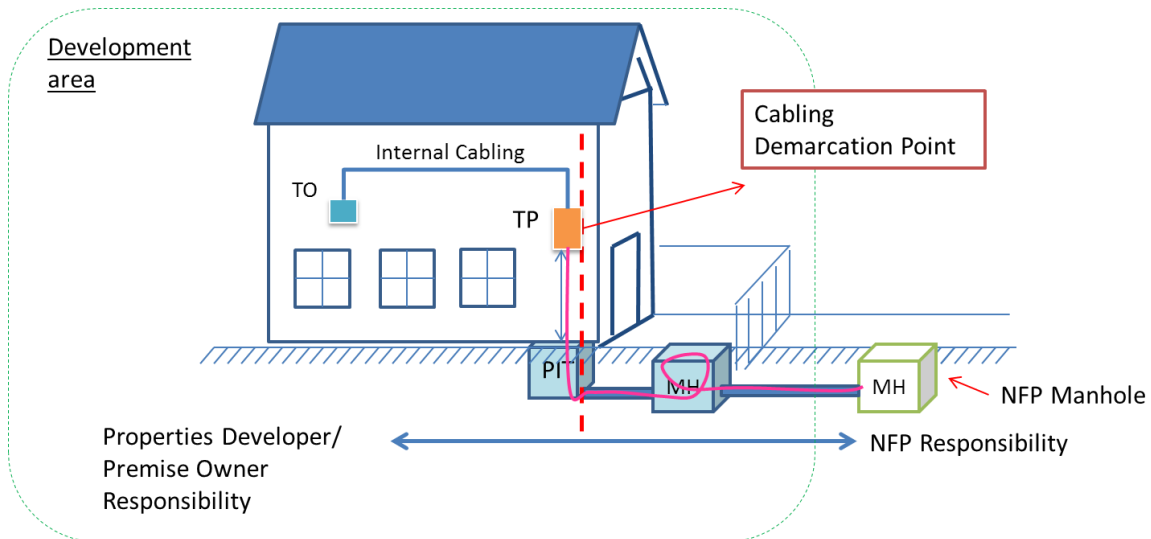

Figure 8. Demarcation Point between Developer and NFP

b) Developer / Premise Owner Responsibilities

All the cabling from TP, including the TP, is under Developer / Premise Owner. Developer / Premise Owner shall prepared the cabling according to the specification. After premise completion, Premise Owner is responsible to maintain and ensure all the cabling is in good condition. Premise Owner is fully responsible for any restoration for any damage.

8.2 Termination Point (TP) - Fibre Termination Box (FTB)

TP for fibre cabling is referred to the FTB. The FTB is located at the building wall acts as the connection point between the NFP’s distribution cables and customer premise internal cabling.

The FTB including all the elements inside it shall be provided by the Developer and shall type approved by certification body and NFP. FTB shall be robust and weather proof especially for outdoor installation. The minimum number of TP inside FTB is two (2) using the SC/UPC connectors.

FTB shall be placed 2.0m to 2.5m from the ground.

If FTB is placed outside of the building, it shall comply with the outdoor environment, according to certification body and NFP recommendation, to sustain minimum 15 years.

Specification of the FTB is explained in Annex A. Sample of the FTB is as shown in Figure 9 below.

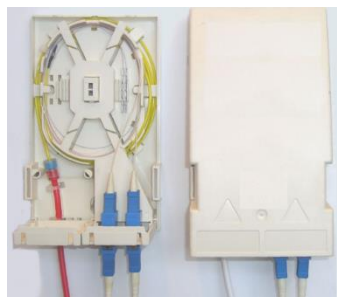

Figure 9. Sample of two (2) cores FTB

MCMC MTSFB TC G006:2016

8.3 Fibre Wall Socket (FWS)

The FWS is a TP for the Internal Fibre Cable and act as a connection point to the CPE.

The FWS shall be provided by the Developer with SC output connector for connection with CPE's patch cord. The CPE patch cord will be provided by the NFP during the service activation.

Minimum one (1) unit of FWS shall be provided by the Developer in all premises. However the number of FWS can be more depend on the number of potential customer in each unit of premise. The FWS and all the elements inside it shall be type approved by certification body and NFP.

The minimum number of TP inside FWS is two (2) using the SC/UPC connectors. The effective fibre core terminated inside FWS is two (2) cores.

The FWS shall equip with shutter at both end adapters to protect internal SC/UPC connector and other end of adapters shall be equipped with dust cap.

The FWS shall be placed at 0.3m above the floor level and 0.3m from the corner of the wall or from electrical points. The FWS shall be made from the non-corrosive material or treated metallic material to resist corrosion.

FTB shall be placed 1.5m to 2.0m from the ground. The sample of FWS is as shown in Figure 10 below.

Specification of the FTB is explained in Annex B.



Figure 10. Sample of FWS

8.4 Internal Fibre Cable

Internal Fibre Cable is referred to the connection cable between FTB and FWS;

Minimum two (2) cores of internal fibre cable shall be prepared between FTB and FWS and connected to both of the SC adaptor inside the FTB and FWS.

The Internal Fibre Cable consists of two (2) cores fibre between two (2) strength members to protect fibre from damage due to the force such as bending, twisting, tensile stress, etc and surrounded by white Low Smoke Zero Halogen (LSZH) sheath.

The cable shall meet all applicable requirement stated in ANSI/ICEA S-104-696, ITU-T, IEC 60794-2 (2002-12) or JIS Standard for Optical Fibre outside Plant Communication Cable, as well as those stated within this specification.

The cable type is ITU-T G.652D Single Mode fibre. However, it is highly recommended to use G.657 - bend insensitive type for Internal Fibre Cable to reduce the fibre loss due to macro bending during the installation work. General specification for G.657 indoor fibre cables is shown in Table 4.

Internal Fibre Cable is used for corridor and indoor cabling. Its structure is shown in Figure 11.

Internal Fibre Cable is suitable for aerial, duct, fixing along with wall, under carpet, installation ways, and its characteristics are as followings:

- a) Small outer diameter, light weight, suitable for branching, indoor, limited room;
- b) Reserved tearing gap of optical cable can separate the fibre easily without instruments, which is convenient to construct; and
- c) Adopting small winding radius fibre with 15mm and even 10mm, suitable for indoor routing under the instance of sudden turning, for instance wall-pole corner and indoor smooth panel.

Table 4. ITU-TG.657 category A attributes

Parameters	Description / Specification				
Mode Field Diameter	8.6µm to 9.5 µm at 1310 nm				
Core Concentricity Error	Maximum 0.5 µm				
Cladding non-circularity	Maximum 1%				
Cladding diameter	125 ± 1 µm				
Attenuation coefficient					
a) 1310 nm ± 1625 nm	Maximum 0.40 dB/km				
b) 1383 nm ± 3 nm	Maximum 0.40 dB/km				
Zero Dispersion Slope	Maximum 0.092 ps/nm ² .km				
Zero Dispersion Wavelength	1300 nm to 1324 nm				
Cable cut-off wavelength	Maximum 1260 nm				
Polarization Mode Dispersion (PMD)	Maximum 0.2 ps/√km				
Fibre proof test level	Minimum 0.69 GPa				
Uncabled fibre macro bending loss	ITU-T G.657.A1		ITU-T G.657.A2		
Radius (mm)	15	10	15	10	7.5
Number of turns	10	1	10	1	1
Maximum at 1550 nm (dB)	0.25	0.75	0.03	0.1	0.5
Maximum at 1625 nm (dB)	1	1.5	0.1	0.2	1

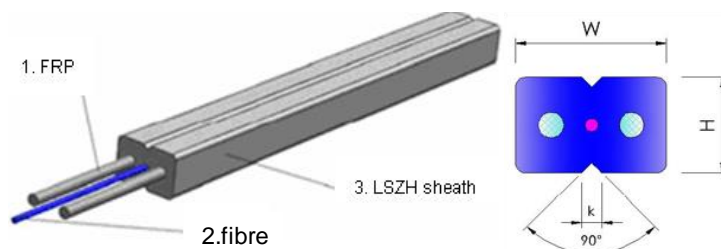

Figure 11. Structure of Internal Fibre Cable

In addition, there are two (2) specifications for this cable (1-core, 2-core), configuring according to different scene requirements.

The main advantages of the indoor flexible optical cables are:

- a) Easy split construction where the jacket can be peeled to open without using any tool;
- b) Fibre is stripped and cleaved using conventional tools;
- c) Readily available compatible interconnection components from multiple international vendors;
- d) Complies to ITU-T and IEC standards; and

MCMC MTSFB TC G006:2016

- e) Multi-fibre core version of the same cable can be used as distribution cable (aerial or underground).

8.5 Cabling Insertion Loss (IL)

Developer shall perform the cabling IL test for all fibre cores between FTB and FWS and provide the test result to the NFP during service provisioning or the infrastructure acceptance process. The total IL for each connection shall not exceed 1.6 dB. The typical elements as show in Table 5 below may be used as reference during cabling planning to ensure the total IL is meeting the specification.

Table 5. Cabling Power Attenuation Loss for SDU – pole type

Location	Item	Unit Loss	Unit	Total Loss	Detail
FTB	FTB: FA-SC Connector	0.7	1	0.7	FA-SC Connector = 0.7 dB
Internal Fibre	Cable (1310 = 0.4 dB/km *)	0.0004	50	0.02	Horizontal Cable (50 m) = 0.02 dB
Inside Premise	FWS: FA-SC Connector	0.7	1	0.7	FA-SC Connector = 0.7 dB
Other	Other Marginal Loss	0.1	1	0.1	Other = 0.1
Total				1.52	Total = 1.52 dB

*ITU-T G.652 reference

8.6 Cabling Design

Fibre cabling is an option depends on the design and the service requirement in the premise. Generally, for buildings that have multiple working areas and each working area require higher bandwidth, fibre cabling should be the most suitable design. Figure 12 below shows the sample of fibre cabling design.

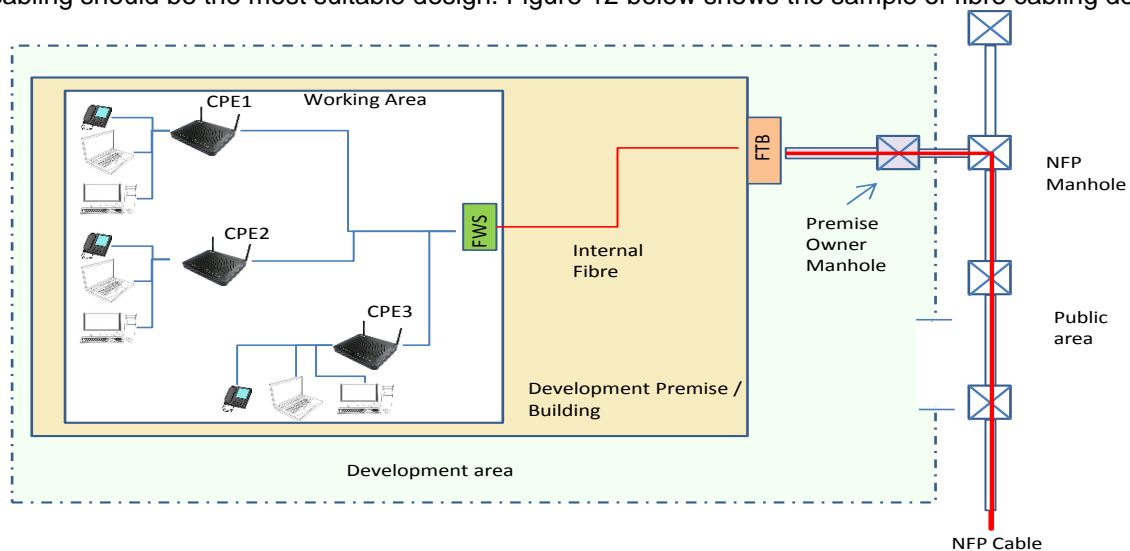

Figure 12. Fibre cabling design

As an option, for building that only requires a basic telecommunication service, structured cabling, as explained in section 9, which only consist of copper cabling might be adopted. For this case, all the CPE shall be installed and located in the TC or TR and the proper cabling and TP shall be prepared accordingly. The entire fibre infrastructure including the cable and all the accessories shall be installed by the NFP together with the CPE during service provisioning. The sample design of structured cabling without any fibre connection is as shown in Figure 13 below.

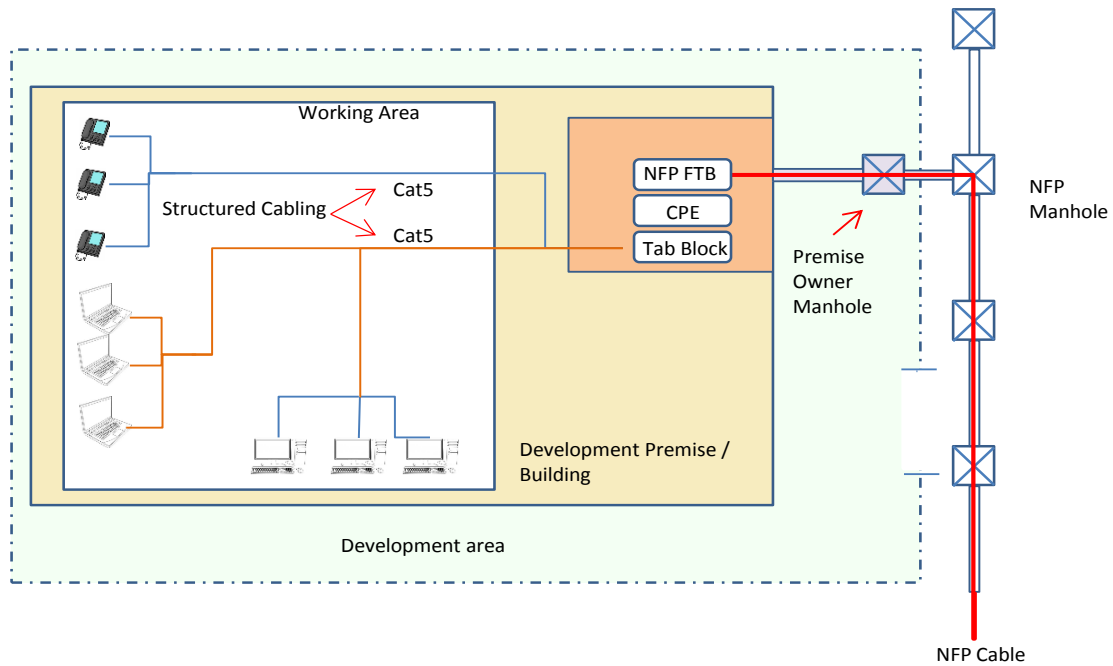

Figure 13. Structured cabling design – without fibre cabling

9. Structured cabling

Structured cabling is referred to the internal copper cabling from the CPE up to the TO which connected to customer's communication device.

Structured cabling may consist of TP, cable and TO.

All material use for the structured cabling shall be Type Approved by certification body and NFP. Type Approved Certificate shall be provided during service provisioning or infrastructure acceptance activities. Failure may impact the NFP to reject the service application.

9.1 Termination Point (TP)

TP acts as the connection point between the NFP's and the in-building cable. It also acts as the distribution point for in-building cabling. The TP shall be located inside the TC or TR.

The arrangement of the element inside the TC is as shown in Figure 14.

The jumper in TC between NFP Copper Block or Broadband CPE and Disconnection Module shall not exceed 500mm.

The voice only service will be terminated at the copper block inside the TC. For Broadband service, NFP may install an active – Broadband CPE, device inside the TC. An ample space – generally 1U space of 19" rack, for the broadband CPE shall be reserved to inside the TC. The CPE types are as below:

- a) Broadband (BB) Modem for Copper Network; and
- b) Optical Network Unit (ONU) for fibre network.

MCMC MTSFB TC G006:2016

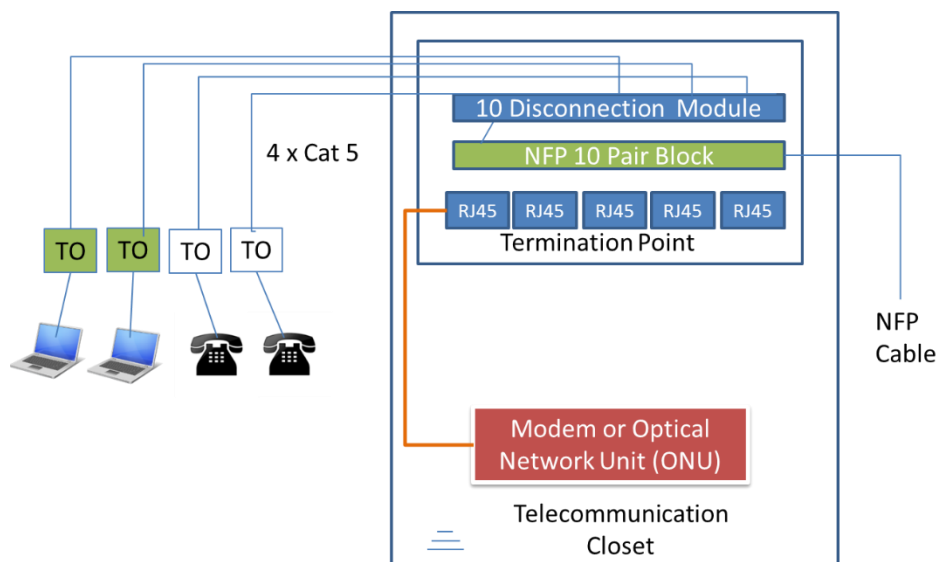

Figure 14. Structured cabling connection diagram

The TC shall contain 13 A of 3 pin plug power socket outlet.

Minimum of 10 Disconnection Module with arrestor for surge protection connected to RJ11 TO via Cat 5e or higher cable shall be installed in the TC. The specification of the Disconnection Module is explained in Annex B.

Minimum of 2 x RJ45 socket connected to RJ45 TO via Cat 5e or higher cable shall be installed in the TC.

Labelling and tagging of each TP with printed and clearly seen tagging material.

9.2 Structured cable

Minimum of 4 x UTP cable - Cat 5e or higher shall be installed between TP to TO. Two (2) of the cables shall be terminated at RJ11 TO and the other two (2) cables shall be terminated at RJ45 socket in work area.

The maximum cabling length from the TP of the cable in the TC to the TO in the work area shall be 90m regardless of the medium.

A total mechanical length of 10m is permitted for work area cables, patch cord or jumpers and equipment cables in any structured cable segment. These mechanical lengths vary according to requirements but shall be consistent throughout the premises.

Cables of different characteristic impedance shall not be mixed within a cabling link.

The preferred cables for internal copper cabling sub-system are as follows:

- 100 Ω balanced cable; and
- 0.5mm copper size.

Specification of copper cable is explained in Annex C.

9.3 Telecommunication Outlet (TO)

TO is referred to the outlet that directly connected to the end user communication device such as telephone set or personnel computer.

TO is higher recommend to be installed on the wall mounted. The position of the TO shall be placed at 300 mm to 400 mm from floor level and shall readily accessible throughout the work area.

To feed the telecommunication device with the electrical power, it is highly recommended to place the TO adjacent to 2 x power socket 3 pin plug 13 A socket outlet.

The minimum number of TO shall be four (4) which shall consists of 2 x RJ11 and 2 x RJ45. TO can be provided together or separately located depending on the working area setup in the premise. The designer shall have the final say on the number of TOs provided that the minimum number of TO rule is not violated. A high density of TO will provide the flexibility of the cabling to cater for future requirement.

If a TO is supported by balanced cable, four (4) pairs shall be provided at each TO with all pairs being terminated. TO shall be marked with a permanent label that is visible to each user. The changes shall be recorded.

Each TO can be configured separately or in single faceplate as shown in Figure 15 below.

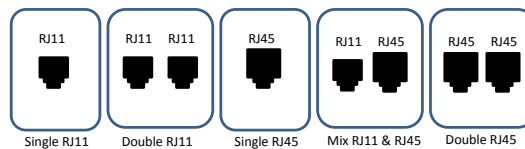

Figure 15. TO socket type

Figure 16 indicate the TO configuration and the pair assignment for 8 position modular jack connecting hardware using T568B wiring pattern respectively.

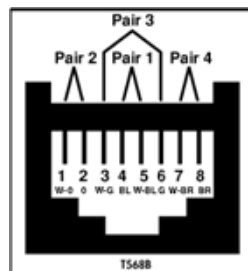

Figure 16. Pair Assignment for T568B

All TO connection in the premise shall be captured in Straight Line Drawing and shall be presented during service activation and infrastructure acceptance process. Sample of Single Line Diagram (SLD) diagram is as shown in Figure 17.

MCMC MTSFB TC G006:2016

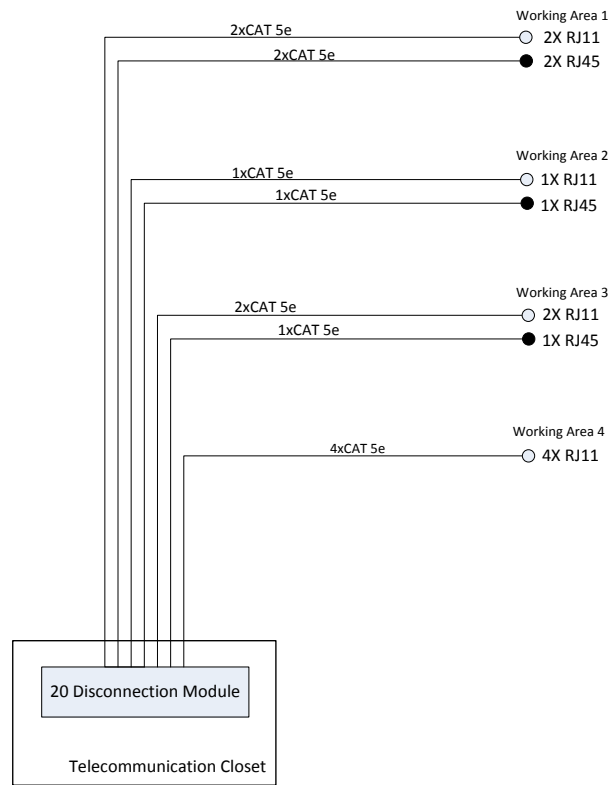

Figure 17. Sample of Structured Cabling SLD Diagram

10. Cabling test

10.1 UTP cabling test

Each cable be tested using the UTP Cable tester – UTP Test Equipment. All of the item as listed below shall be tested to ensure all the cabling are in good condition and able to support services as require by NFP and meet the EIA/TIA 568 standard:

- Wiremap Test;
- Performance Test - Return loss, Crosstalk, Cable Attenuation test; and
- Length measurement.

The test equipment for system certification should comply with Level IIE-Test Equipment. Level III Test Equipment is recommended. The Test Equipment shall be initialized before use.

10.2 Wiremap Test

Figure 18 shows the sample of wiremap tester to verify cable continuity, short, open and crossed wire pairs.

Wiremapping is a simple test that confirms each wire is hooked up correctly, with no opens or shorts. Each pair shall be connected to the correct pins at the plugs and jacks, with good contacts in the terminations. A "wiremapper" is basically a continuity checker that determines if pins are correctly connected.



Figure 18. Wiremap Tester

Length measurement - Since EIA/TIA 568 cables shall be less than 90m (296ft) in the permanent link and 100m in the channel (328 ft), cable length shall be tested using the Time Domain Reflectometer (TDR) or Cable Certifier.

10.3 Performance Test

To verify the performance of the UTP cable, generally LAN Verifier Equipment is highly recommended. This test is to ensure the prepared cabling are able to support higher bandwidth service.

Performance testing for attenuation, crosstalk, etc. requires testing over the full frequency range of the cable. The frequency range for each cable type is:

- a) Cat 3: 16 MHz;
- b) Cat 5/5e: 100 MHz;
- c) Cat 6: 250 Mhz; and
- d) Cat 6A: 500 MHz.

Attenuation test requires a tester at each end of the cable, one (1) to send and one (1) to receive, then one (1) of them will calculate the loss and record it. There are pass/fail criteria for the cable at Cat 3, 4, 5, 5e, 6 and 6A maximum frequencies. Here is how typical cable attenuation changes with frequency.

Cat 5e/6 testers measure crosstalk from one (1) pair to all three (3) other pairs for each pair and compare it to the 568 specs, giving a pass/fail result. Some also calculate ACR as it is a measure of how big the crosstalk signal is to the attenuated signal at the receiver. You want this number as big as possible, as it is an indication of the signal to noise ratio.

10.4 UTP Testing Procedures

The testing procedures as below:

- a) Test shall be done on every single cable from Point to Point (P2P), i.e from patch panel to TO.
- b) At the end of the installation, structured cabling cable pairs of Cat 5 cables shall be tested from the Telecommunications Point to the TO.

MCMC MTSFB TC G006:2016

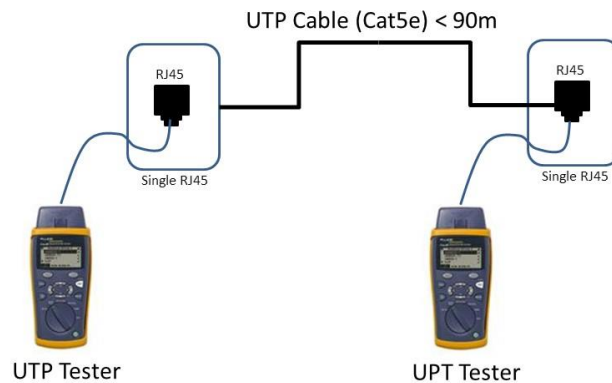

Figure 19. Permanent link testing configuration

Permanent link testing configuration is as shown in Figure 19.

For Cat 5e cables, the following permanent link test shall be performed:

- a) Insertion Loss
- b) Near End Crosstalk (NEXT)
- c) Powersum NEXT
- d) Equal level far end crosstalk (ELFEXT)
- e) Powersum ELFEXT
- f) Return loss
- g) Delay Skew
- h) ACR

Any pairs not meeting the requirements of the standard shall be brought into compliance.

10.5 Insulation Resistance (IR) test

This test shall be carried out for two (2) pairs per unit for cables of unit construction or two (2) pairs per layer formatting. In all cases the minimum number of pairs to be tested shall be ten (10) pairs. The IR test connection is as shown in Figure 20.

IR test on Cable End:

- a) The IR test shall be measured with a 500 V DC Test Meter. The IR of each wire (including stumped pairs) in the cable shall be measured with all other wires, and screen connected to earth and the measurements recorded. The Guard facility of the IR Test Meter shall be used in order to avoid the effects of leakage current during measurement.
- b) For this test all equipment connected to the cable at the TP and the field mounted carrier frequency equipment shall be disconnected. The pairs used to feed power remote from the any source shall have the power disconnected. All wires at the far end shall be opened.
- c) After steady electrification for one (1) minute the IR of each conductor in the cable measured with all other conductors and screen connected to earth shall not be less than 1500 M Ω kilometre at ambient temperature. The measurement to be made to the nearest M Ω wherever possible.
- d) If the conductor fails to meet the minimum requirement, then that pair is classified as a faulty pair unless the defect is rectified or proved to be due to any associated equipment.

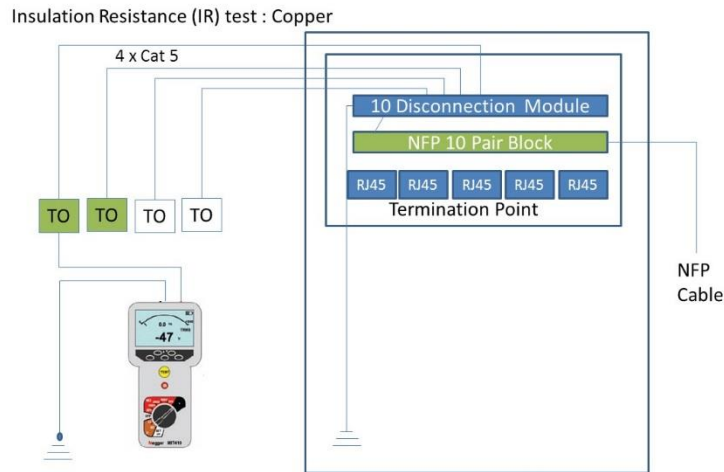

Figure 20. Insulation Resistance (IR) test connection

10.6 Conductor Resistance (CR) test

All conductors should be tested for continuity and the loop resistance of each pair should be recorded. The measured value of all pairs should be within 10% of the calculated value. The calculated value is based on the cable length as determined from the length installed, standard conductor resistance and adjusted to the temperature at the time of measurement as shown in Figure 21 below.

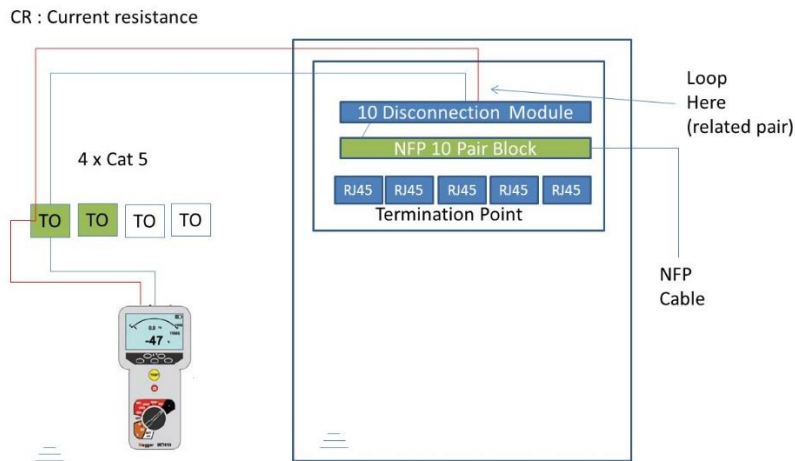

Figure 2119. Conductor Resistance (CR) test

For stumped pairs, conductor resistance test should preferably be done prior to closing the joint, i.e. before final commissioning tests for completed cable system. Readings shall be recorded and submitted formally to the Superintending Officer as soon as possible. For calculation purposes, the standard resistance for single copper conductors at 20°C shall be as given in the Table 6.

MCMC MTSFB TC G006:2016

Table 6. Standard resistance for single copper conductors

Conductor Diameter (mm)	Resistance (in ohms) per km of cable at 20°C (single wire)
0.4	143
0.5	91
0.63	58
0.9	28
1.27	14

The temperature co-efficient of resistance (copper conductor) is 0.0039/°C.

10.7 Fibre Cabling test

For the building that has been installed with the fibre cabling, each connection of the fibre shall be tested to ensure it is in working condition and meeting the NFP specification. Generally, only IL test require to be performed. NFP may require additional test depend on their requirement.

IL test is performed to measure the total loss between FTB and FWS. It should inclusive of the connector loss inside the FTB and FWS, cable loss and also any jointing loss between that connector. IL is measured in dB unit and the allowable IL loss between FTB and FWS is 1.6 dB.

To measure IL, generally the test gear as below is used:

- Optical Loss Test Set (OLTS);
- Power Meter together with Light Source; and
- Optical Time Domain Reflectometer (OTDR).

All the cabling should be connected as shown in Figure 22 below, to perform the IL test.

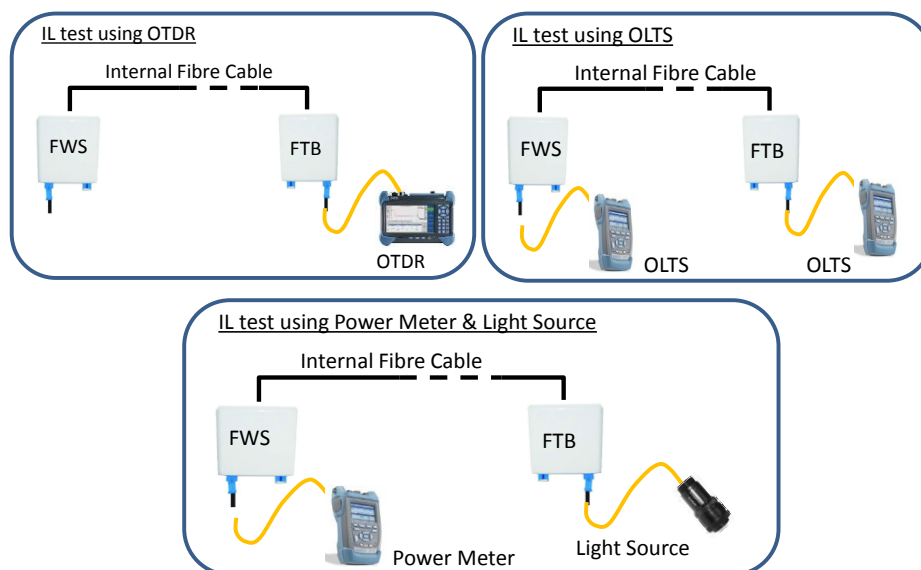

Figure 22. Insertion Loss (IL) setup

Each fibre cores test result shall be captured and presented during service activation or infrastructure acceptance process. Test result shall be recorded using the format as shown in Annex D.

11. Infrastructure and cabling acceptance procedure

The Developer shall engage a contractor certified by Occupational Safety and Health (OSHE) and Construction Industry Development Board (CIDB) certified contractor for all the telecommunications infrastructure and cabling works for the development areas.

The Developer to ensure all relevant permits are obtained and to be in compliance with all the relevant safety requirements.

11.1 Timeline to provide services

Developer or Premise Owner shall submit or engage with selected NFP for the NFP infrastructure connection 90 days before service installation target date.

Upon the completion of the infrastructure and the cabling, Premise Owner shall submit the service application form to NFP 14 days before service installation target date.

The Developer to notify appointed NFP with 7 days written notice.

11.2 Service application process flow

The process flow of getting the approval and service from NFP is as shown in Table 7 below.

Table 7. Infrastructure approval and service activation process

Simple Development : Overall Process for Approval and Deployment		
DEVELOPER		a) Developer to inform selected NFP with Letter of Award (LOA) and submit the following: i. Telecommunication Infrastructure plan ii. Type and Quantity of Service iii. Proposed service date b) NFP to provide Letter of Confirmation (LOC) to provide the service
NFP		c) Developer to submit documentation according to the checklist in section 11.3, 2 weeks before service activation service date. d) NFP to process order: Set installation and appointment date e) Service Activation

Both parties shall adhere to the agreed acceptance procedure.

The acceptance procedures and processes should be performed and completed on the same day.

The Developer to prepare all the documentations required for all the processes for the acceptance procedure

The acceptance procedure is to be performed once the development progress is 95% completed.

The NFP shall issue Certification of Acceptance upon completion of acceptance procedure.

The Developer to prepare all the necessary tools and test gear and all the relevant officials/ personnel are required to presence during the acceptance procedure.

MCMC MTSFB TC G006:2016

11.3 Documentation

Developer or Premise Owner is required to submit all documents as listed below:

- a) Acceptance checklist endorsed by consultant or contractor;
- b) As Built and Cabling Schematic Line Diagram;
- c) Cable test result;
- d) Internal and external infrastructure plan – sample as explain in Annex E;
- e) Calibration certificate of test gear; and
- f) NFP Type Approve Certificate of each material used

During the infrastructure acceptance process, if necessary, NFP will issue the Certificate of Acceptance (COA) if all of the requirement were fulfilled according the requirement.

Annex A
(normative)

Normative references

ANSI/ICEA S-104-696, *Standard for Indoor-Outdoor Optical Fibre Cable*

BS6651, *Code of practice for protection of structures against lightning*

EIA/TIA 568, *Standards for telecommunications cabling systems*

IEC 352-4, *Solderless connections Part 4: Solderless non-accessible insulation displacement connections - General requirements, test methods and practical guidance*

IEC 60529 Ed. 2.1, *Degrees of protection provided by enclosures (IP Code)*

IEC 60825-1 Ed 2.0, *Safety of laser products - Part 1: Equipment classification and requirements*

IEC 60364-1, *Low-voltage electrical installations - Part 1: Fundamental principles, assessment of general characteristics, definitions*

IEC 60794 - 2 (2002-12), *Optical fibre cables - Part 2: Indoor cables - Sectional specification*

ISO 2081, *Metallic and other inorganic coatings -- Electroplated coatings of zinc with supplementary treatments on iron or steel*

ITU-T.G.652D, *Characteristics of a single-mode optical fibre cable*

ITU-T G.657, *Characteristics of a bending-loss insensitive single-mode optical fibre and cable for the access network*

Annex B
(normative)

Fibre Termination Box (FTB) and Fibre Wall Socket (FWS) Specifications

- B1. The termination box shall be suitable for attachment to inside or outside wall of a building.
- B2. The material shall be able to protect the component against harsh, high heat and humidity environment. The termination box shall be designed and conforms to IP44 of IEC 60529 Ed. 2.1 standards or better for indoor application and IP55 of IEC 60529 Ed. 2.1 standards or better for outdoor application.
- B3. Evidence (such as certificate, letter of conformance, etc) from certification body or authorized body shall be provided during approval process.
- B4. The termination box shall be suitable for 19" rack-mount and/or wall mounted. The offered termination box shall be complete with its respective mounting kits.
- B5. The framework of the high density and medium density FTB shall be fabricated from electro-galvanised steel or rust proof steel plating of thickness not less than 2.0mm and the design shall conforms to ISO 2081 or other recognized standards.
- B6. The framework of the premise FTB and fibre socket shall be plastic injection moulded or thermoplastic and made of fire retardant material. All the plastic material shall have a rating of V-1 or better as determined by Underwriters Laboratories' UL94 standard.
- B7. The FTB shall be design with built-in splitter or without splitter.
- B8. All edges shall be rounded.
- B9. Total weight of the FTB including full accessories shall be suitable for wall mounting.
- B10. Maximum overall dimension shall be 16" (H) x 18" (W) x 6" (D) [406mm (H) x 457mm (W) x 152mm (D)] for high density termination box.
- B11. Maximum overall dimension shall be 8" (H) x 5" (W) x 1.5" (D) [203mm (H) x 127mm (W) x 38mm (D)] for customer premise termination box.
- B12. The developer shall propose separate sizes and capacity to provide cable management and connection for high, medium, low and individual premise fibre installation including fibre socket.
- B13. The developer shall furnish details specification and characteristic of the various sizes of the FTB and fibre socket offered during the submission of proposal for evaluation.
- B14. The developer shall submit proposed technical drawings complete with dimensions for the product offered.
- B15. The FTB shall consist of moulded inner fibre slack storage, sleeve holder and integral positive lock strain relief for cable and other accessories deem necessary.
- B16. The FTB design shall have suitable splice tray and cable management area to provide for minimum bending radius and for storage ruggedized splitter pigtails.

MCMC MTSFB TC G006:2016

- B17. Suitable number of splice organizers trays or splice trays shall be provided in the splice compartment. The splice tray shall be of cartridge or cassette types that are stackable and flappable or able to be opened sideways.
- B18. The number of trays and other appropriate accessories provided shall suit the maximum number of cores of the fibres intended to be installed. The splice tray shall comply with GR-771.
- B19. The FTB shall have pre-assembled plates with SC coupling for fibre patching.
- B20. It shall be designed with two (2) physically separated compartments to isolate the incoming cable (capable of accommodating splitter where needed) from the Drop Fibre compartment.
- B21. The door opening shall be designed for suitable operation in confined space.
- B22. The FTB shall be provided with various sizes of cable entries at both top and bottom. All cable entries shall be provided with rubber grommets to protect the cable and prevent pest and dirt entry.
- B23. The rubber grommets shall have suitable guides for different cable sizes to permits pass through of additional fibres.
- B24. The FTB design shall be economical, effective, robust and compact to provide access point for Drop Fibre and Internal Fibre.
- B25. Each FTB shall be provided with a table or label card for circuit identification purpose. The table shall be printed on durable material in such a manner as to be permanently legible, protected by an acrylic pocket and properly displayed on the inside cover of the termination box.
- B26. Approved laser caution signs as per IEC 60825-1 Ed 2.0 requirements shall be provided as standard for every termination box.
- B27. The termination offered and its associated hardware shall be commercially available (in current production) and already been commercially deployed. Any prototype and unproven System shall be disqualified. Developer to submit evidence to prove the systems are field proven and in current production.
- B28. An inventory list containing lists of components or parts supplied and operation and installation manual shall be provided with each termination box.

Annex C
(normative)

Technical Specification for 10 Pair Disconnection Module

I. Type-1

C1. Construction and specifications

- C1.1 Disconnection Module should be designed for 10 pairs and capable of terminating cable wires at access protected side via IDC technique and shall have disconnection facility which can be isolated by inserting disconnection plug or test cord for test purpose. It shall be possible to provide break, short, earth for testing and extending line wires and exchange wires separately to the test desk or test instrument without disturbing the IDC contact by using suitable plug inserts.
- C1.2 All Disconnection Module should carry the respective (registered) trademark. Disconnection Module shall be of disconnection type and the colour shall be white.
- C1.3 Disconnection Module shall meet the required international connectivity standard in accordance to IEC 352-4 and should have a minimum service life span of 20 years.
- C1.4 The cable and the conductor diameter to be terminated on the Modules are given below:
- a) Conductor diameter: 0.4mm to 0.8mm.
 - b) Insulated wire diameter: 0.7mm to 1.5mm.
- C1.5 The mounting of the Disconnection Module should be designed for a universal use, Profile rods and Back-mount frames.
- C1.6 The contact tags are arranged at an angle of 45 degrees to the axis of the wire. Using the Sensor Insertion Tool, the wire is forced open into the contact slot between the two flexible contact tags.
- C1.7 The tags open in an axial direction and are twisted at the same time. This action displaces the insulation and the tags grip the central conductor at two staggered points.
- C1.8 Owing to the dislocation of the material at the connection and the restoring forces of the contact tags, a permanent gas tight area is created between the tags and the conductor.
- C1.9 Additional protection of the contact area, against shock and tensile forces is provided by plastic clamping ribs, which grip the wire on both sides thus maintaining the mechanical integrity of the joint.
- C1.10 The terminal module shall have necessary in-built arrangement for fanning out cable pairs in sequential order.
- C1.11 The IDC contacts of cable wires and jumper wires shall be available from front side of the terminal block for easy handling. The termination of wires shall have to be carried out from the front side of the terminal module.
- C1.12 It shall be possible when necessary to add a parallel wire to any terminated jumper wire in a module. All IDC connection shall be made using proper insertion tool termed as Sensor Insertion Tool.

MCMC MTSFB TC G006:2016

C1.13 When needed, single pair protection with over-voltage and over-current or protection magazines with over-voltage should be applied on the modules.

C1.14 The protection magazines shall include 3 pole arresters with fail-safe springs with the following technical properties:

No.	Item	Condition	Standard
1	DC spark-over voltage	100V/s	230V ± 20%
2	Impulse spark-over voltage	100V/μs	≤ 500V
		1kV/ μs	≤ 650V
3	Insulation resistance	100V DC	≥ 10,000MΩ
4	Capacitance	1MHz	≤ 3.0pF
5	DC Holdover Voltage	80V, 330Ω	≤ 150ms
6	Impulse Life	10/1000μs, 400A	300 times
7	Impulse Discharge Current, 8/20 μs	Single	20kA
		Repeat 10 times (5 times each polarity)	10kA
8	AC Discharge Current, 50Hz	Single (9 cycles)	130A
		Repeat 10 times (1 second)	10A
9	Operating temperature		20°C to + 80°C

Notes:

All these parameters will be tested as per ITU-T Recommendation K.12

C1.15 The gas in the arrester should not be radioactive. Also, for the protection against high voltage, there should be a grounding system between the modules and the frame(s).

C1.16 The universally mountable Modules should be easily assembled and disassembled to the Back Mount Frame and the Round Bar Frame (Profile Rod) without any special tool requirements. When the removed Module is refitted again to the frame, there should not be a gap or looseness.

C1.17 The contact elements as well as the cable side contacts - when are installed in the frames - should be protected against unintentional contact in order to avoid electrical hazards and to secure integrity of cabling.

C1.18 There should be a guide for the cable pairs and jumper wires for proper connection.

C1.19 Product part no. and the year of manufacture should be embossed or printed clearly on the cabling side of the modules and it should be non-erasable.

C1.20 At the front side of the module there are the numbers from 1 to 0 (10) printed and it should be non-erasable.

C1.21 By using the Sensor Insertion Tool, the cable wires should be connected to the IDC contact without removing the insulation and cutting the wires prior to the termination, forming a gas-tight, self-locking contact complying with IEC 352-4.

C1.22 The Sensor Insertion Tool inserts the conductor into the contact slot and cuts the excessive length of the wire. It should feature a facility to remove the wires from the contact slot. The insertion operation should be done with a defined force. All parts (blades and cutters) of the

MCMC MTSFB TC G006:2016

insertion tool should be made from hardened steel and it should be nickel plated as per DIN 1544.

- C1.23 The Sensor Insertion Tool shall have a service life of:
- a) 0.4mm...200,000 connections
 - b) 0.5mm...100,000 connections
 - c) 0.8mm...50,000 connections
- C1.24 The modules shall function reliably between -20°C and +80°C.
- C1.25 Accessories: The following accessories will be used together with the system (if there are other accessories required, this shall be mentioned in the offer.)
- a) Hinged Label holder;
 - b) Test cord;
 - c) Marking plugs;
 - d) Disconnection plug (red); and
 - e) Sensor Insertion Tool.
- C1.26 The modules should have the facility to be tagged with numbers to allow easy identification of the terminated cable.
- C1.27 Construction of the contact elements shall be copper alloy: The contacts will be in U-shaped with high electrical and mechanical capacity. The contacts will be silver coated. The thickness of the coating shall be minimum 5.0 micron at the contact area. This thickness shall be 0.5 micron at other parts of the contact element. The cable contacts and jumper contacts are to be arranged in an angle of 90°.
- C1.28 The Disconnection Module should be able to withstand a wire connection frequency of at least 200 times per termination slot.
- C1.29 Construction of the upper and lower plastic housing material shall be Thermoplastic Polyester. The material will be self-extinguishing type with an Oxygen Index of > 28% (VO acc. to UL-94, self-extinguishing when the heating source is taken away). It should be resistant against deterioration caused by jelly material from jelly filled cables, PVC-softener, chemical cleaning materials, alcohol etc. and should not engage any chemical reaction with such materials.

II Type-2

C2. Construction and specifications

- C2.1 Disconnection Module should be designed for 10 pairs and capable of terminating cable wires at access protected side via IDC technique and shall have disconnection facility which can be isolated by inserting disconnection plug or test cord for test purpose. It shall be possible to provide break, short, earth for testing and extending line wires and exchange wires separately to the test desk or test instrument without disturbing the IDC contact by using suitable plug inserts.
- C2.2 All Disconnection Module should carry the respective (registered) trademark. Disconnection Module shall be of disconnection type and the colour shall be white casing on light grey base.
- C2.3 The material used should be from high quality thermoplastic material self-extinguishing, complies with UL94 V-0. It should be resistant against deterioration caused by jelly material from jelly filled cables, PVC-softener, chemical cleaning materials, alcohol etc. and should not engage any chemical reaction with such materials.
- C2.4 The contacts should be construct from tin lead plating* over an under lead copper for bronze contact
- C2.5 IDC contact should be designed to withstand multiple re-terminations and accommodate the following range of wires:
 - a) Conductor gauge: from 0.4mm to 0.8mm;
 - b) Solid copper conductor; and
 - c) Maximum overall diameter: 1.8mm max.
- C2.6 A specific termination tool which is compatible with Type-2 should be design for punching the wire onto IDCs, cutting the extra length of wire as well as removing a wire from the IDC.
- C2.7 When needed, single pair protection with over-voltage and over-current or protection magazines with over-voltage should be applied on the modules.
- C2.8 The protection magazines shall include 3 pole arresters with fail-safe springs with the following technical properties:

No.	Item	Condition	Standard
1	DC spark-over voltage	100 V/s	230 V ± 20 %
2	Impulse spark-over voltage	1 Kv/μs	≤ 90 V
3	AC Discharge Current	50 Hz 1sec 5A x 2	5 times
4	Impulse Current or or	8/20 (μS) 5KA x 2 10/700 (μS) 100A x 2 10/1000 (μS) 100A x 2	10 times 500 times 300 times
5	Residual Voltage Glow Voltage Arc Voltage	Few mA 2 A	< 300 V < 25 V
6	Transverse Voltage	1 KV/μS	< 200 ns
7	Hold Over Voltage	CCITT K12 Test 3	> 135 V
8	Insulation Resistance	100V DC	> 1G ohm

MCMC MTSFB TC G006:2016

No.	Item	Condition	Standard
9	Capacitance	1 KHz	< 5 Pf
10	Radiation		Non radiation
11	Fail-safe Mechanism	5A x 2	< 5 sec
12	Operating Temperature		20°C to + 80°C

Notes:

All these parameters will be tested as per ITU-T Recommendation K.12

- C2.9 The gas in the arrester should not be radioactive. Also, for the protection against high voltage, there should be a grounding system between the modules and the frame(s).
- C2.10 The universally mountable Modules should be easily assembled and disassembled to the Back Mount Frame and the Round Bar Frame (Profile Rod) without any special tool requirements. When the removed Modules are refitted again to the frame, there should not be a gap or looseness.
- C2.11 The contact elements as well as the cable side contacts – when are installed in the frames – should be protected against unintentional contact in order to avoid electrical hazards and to secure integrity of cabling.
- C2.12 There should be a guide for the cable pairs and jumper wires for proper connection.
- C2.13 Product Part No. and the year of manufacture should be embossed or printed clearly on the cabling side of the modules and it should be non-erasable.
- C2.14 At the front side of the module there are the numbers from 1 to 0 (10) printed and it should be non-erasable.
- C2.15 The modules shall function reliably between – 20°C and + 80°C.
- C2.16 Accessories - the following accessories will be used together with the system (if there are other accessories required, this shall be mentioned in the offer.)
- a) Hinged label holder;
 - b) Test cord;
 - c) Marking plugs;
 - d) Disconnection plug (red); and
 - e) Sensor Insertion Tool.
- C2.17 The modules should have the facility to be tagged with numbers to allow easy identification of the terminated cable.
- C2.18 Construction of the contact elements shall follow these requirements:
- a) Semi rigid IDC contact;
 - b) Staged contact;
 - c) Core material - bronze;
 - d) Thickness of contact - 0.8mm;
 - e) Surface protection - tin / lead plating over copper; and
 - f) High pressure contact - mechanical resistance of the contact against opening.

C2.19 Where else, the contact area should meet the following specifications:

- a) Gastight;
- b) Typical contact resistance with a 0.5 gauge : $1\text{m}\Omega$;
- c) Dielectric strength $> 6000\text{ V}$; and
- d) No reaction with Hydrogen Sulfide (H_2S) - Sulfur Dioxide (SO_2) test.

C2.20 The Disconnection Module should be able to withstand a wire connection frequency of at least 200 times per termination slot.

Annex D
(normative)

Copper Cable Specification

- D1. The recommended internal (indoor) cables are the PVC Insulated and sheathed copper cables that adheres to NFP specification.
- D2. Conductor - unless otherwise specified, tinned annealed copper wire, having a nominal diameter and maximum resistance in accordance with Table D1 below.
- D3. Insulation - Hard Grade PVC compound with thickness as shown in Table D1 and uniformly coloured in accordance with Table D2 below.

Table D1. Insulated conductors - dimensions and resistance

Insulated conductors dimension and resistance				
Nominal diameter of wire (mm)	D.C. Resistance at 20°C (ohms/km)		Nominal Radial Thickness of insulation (mm)	Nominal Overall diameter of insulated conductor (mm)
	Maximum Average	Maximum for 99% of cases		
0.5	89.55	91.4	0.25	1
0.63	56.42	57.72	0.25	1.13

Table D2. Colour scheme for pairs

Colour scheme for pairs			
Pair Number	Colour of conductor insulation		
	A leg (1 st wire)	B leg (2 nd wire)	
1	White	Blue	} First 5 pair unit
2	White	Orange	
3	White	Green	
4	White	Brown	
5	White	Grey	
6	Red	Blue	} second 5 pair unit
7	Red	Orange	
8	Red	Green	
9	Red	Brown	
10	Red	Grey	
1 pair only	White	Orange	
3 wires	White	Orange	
			Green

- D4. Twinning – two (2) insulated conductors twisted together to form a pair with colour in accordance with Table D2.

D5. Tripling - three insulated conductors twisted together to form a triple with colour in accordance with Table D2.

D6. Construction:

- a) Up to 10 pairs cables: twisted pairs stranded to form compact bunch strand.
- b) Above 10 pairs cables: consist of 5 pairs or 10 pairs sub-unit.

Table D3. Colour of binder tapes

Colour of binder tapes – 10 pair unit	
Unit Number	Colour of Binder
1, 1A, 11	Blue
2, 2A, 12	Orange
3, 13	Green
4, 14	Brown
5, 15	Grey
6, 16	Blue-White
7, 17	Orange-White
8, 18	Green-White
9, 19	Brown-White
10,20	Grey-White

Notes:

Units 11-20 only apply to 200 pairs cable

D7. Lay-Up - Units and sub-units stranded together to form a compact and symmetrical cable core.

D8. Sheath - Extruded Grey Hard Grade PVC compound with sheath thickness as shown in Table D3.

Annex E
(normative)

Insertion Loss Test Result

Building Name	Gudang ABC						
Internal Cable	Indoor Cable x 8						
FTB Rack / Sub-rack No.	FTB1						
Test Item			Insertion Loss (IL)				
Test Direction							
FTB Adaptor No	Work Area	Floor No.	1310 nm (dB)	1550 nm (dB)	1310 nm (dB)	1550 nm (dB)	Distance (Meter)
No. 1	A – FWS1	1	1.1	0.9	1.1	0.9	50
No. 2	A – FWS1	1	1.1	0.9	1.1	0.9	50
No. 3	A – FWS1	1	1.0	0.8	1.0	0.8	50
No. 4	A – FWS1	1	0.9	0.8	0.9	0.8	55
No. 5	A – FWS1	2	1.1	0.9	1.1	0.9	70
No. 6	A – FWS1	2	1.1	0.9	1.1	0.9	70
No. 7	A - FWS2	2	1.0	0.8	1.0	0.8	70
No. 8	A – FWS2	2	0.9	0.8	0.9	0.8	70
Remarks							
Tester							
Verified by NFP							

Annex F
(normative)

Sample of Development Plan

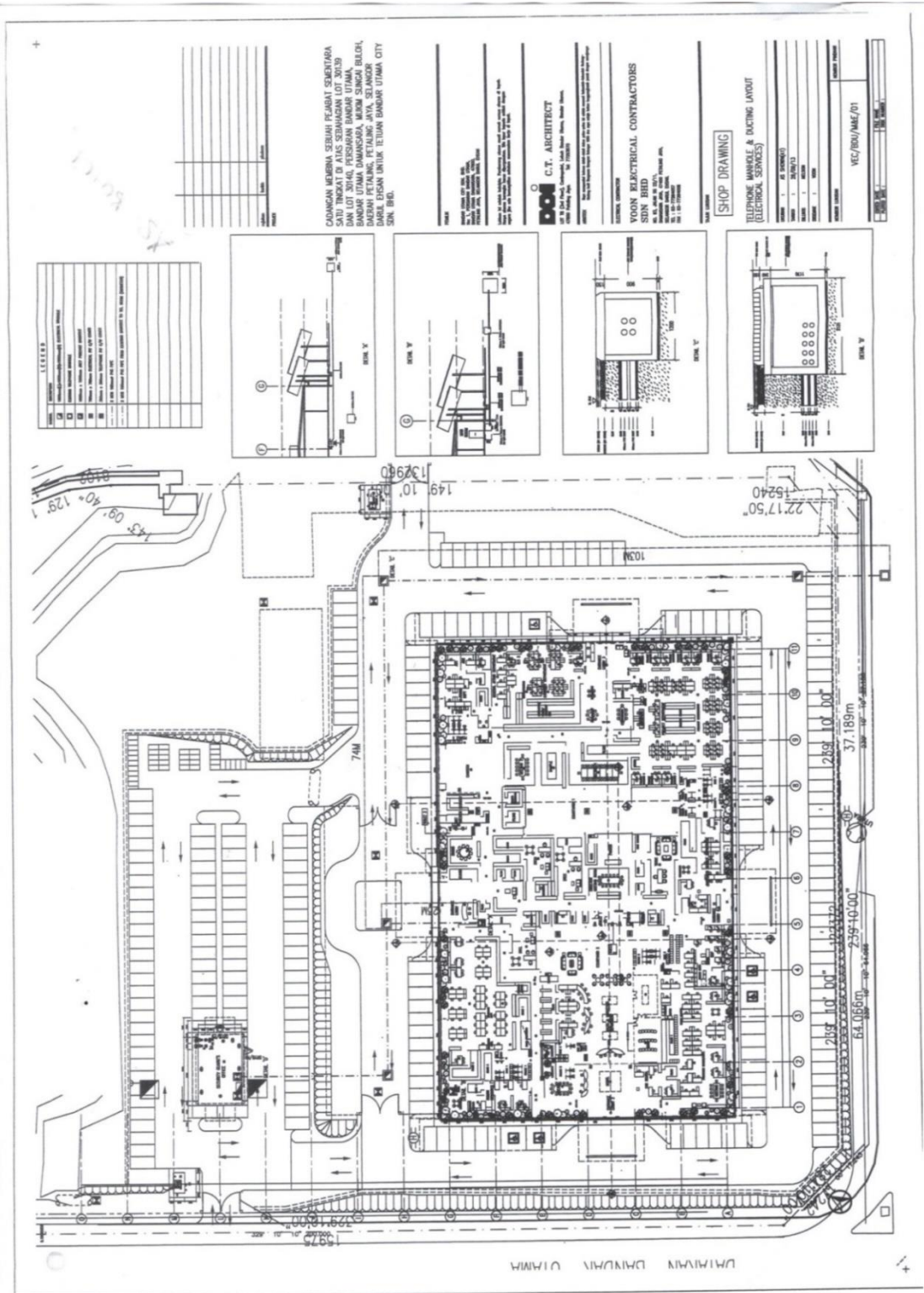

MCMC MTSFB TC G006:2016

Acknowledgements

Members of the Fixed Network Facilities Working Group

Mr. Mohd Yusairi Abu Hassan (Chairman)	Telekom Malaysia Berhad
Mr. Muhammad Mohd Yunos (Vice Chairman)	Time dotCom Berhad
Ms. Nurulfahmie Hj Mohamed Yasin (Secretary)	Telekom Malaysia Berhad
Mr. Abdul Malik Ahmad Jidin/ Mr. Asnizar Firdaus Adini/ Mr. Zamzuri Zainuddin	Jaring Communications Sdn Bhd
Ms. Azlin Ab Manas/ Mr. Mohd Wahid Sabran	Maxis Communications Berhad
Mr. Abdul Rashid Ahmad/ Mr. Azman Ismail/ Ms. Fatimah Salwani Ramli/ Mr. Hermie Md Tahir/ Mr. Mohd Ariff Arifen/ Mr. Zulkifli Rehu	Telekom Malaysia Berhad
Mr. Inderjit Singh/ Mr. Mohd Zakir Bajuri/	Time dotCom Berhad